



Europäisches
Patentamt
European
Patent Office
Office européen
des brevets

Computer-implemented inventions at the European Patent Office

the presentation reflects the personal opinion of the author

Sabine Kruspig
Director Dir2211

Prague, 12 October 2010

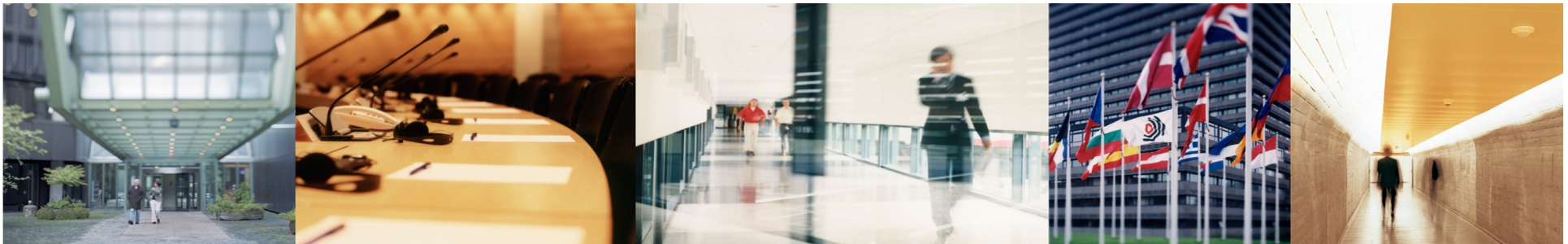

Overview

1. History of computer-implemented inventions
2. The EPO
3. Substantive patent law at the EPO
4. Patentability of computer-implemented inventions
5. Pros and cons of patents
6. Patents as source of information

Calculating machines in the 1930s

385.630 COMPLETE SPECIFICATION

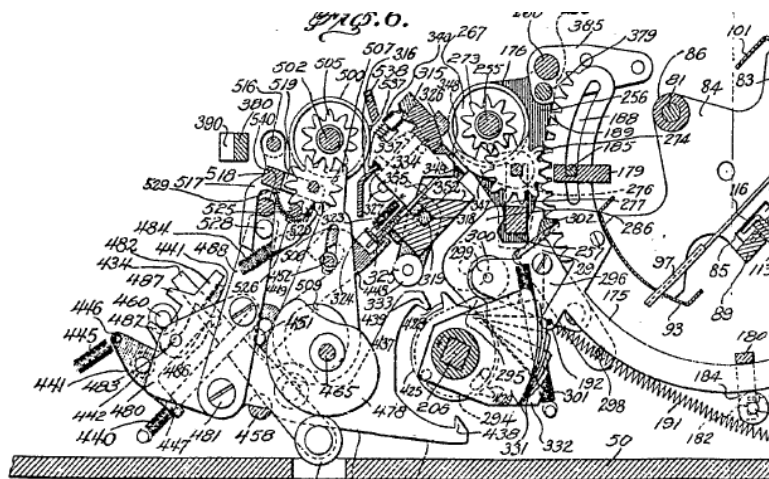
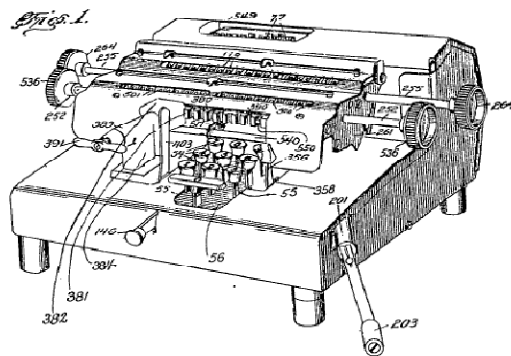

Uitgegeven de
 26. JAN 1933
PATENT SPECIFICATION



Convention Date (United States): March 3, 1931.

385,630

Application Date (in United Kingdom): June 22, 1931. No. 18,001/31.

Complete Accepted: Dec. 22, 1932.

COMPLETE SPECIFICATION.

Improvements in Calculating Machines.

We, **SUNDSTRAND CORPORATION**, a corporation organized and existing under the laws of the State of Delaware, United States of America, located at the Corner of Harrison and 11th Streets, Rockford, State of Illinois, United States of America, do hereby declare the nature of this invention and in what manner the same is to be performed, to be particularly described and ascertained in and by the following statement:—

This invention relates to that type of

In straight adding operations, the actuators are advanced differentially according to the values of the set elements, and one of the main objects of the invention is to enable the operator to effect a relative adjustment between the field of elements and the group of actuators, whereby to enable the elements, set, it will be remembered, according to the actual value of the amount to be registered, to control the excursions of the elements, according to the complement of such amount.

History

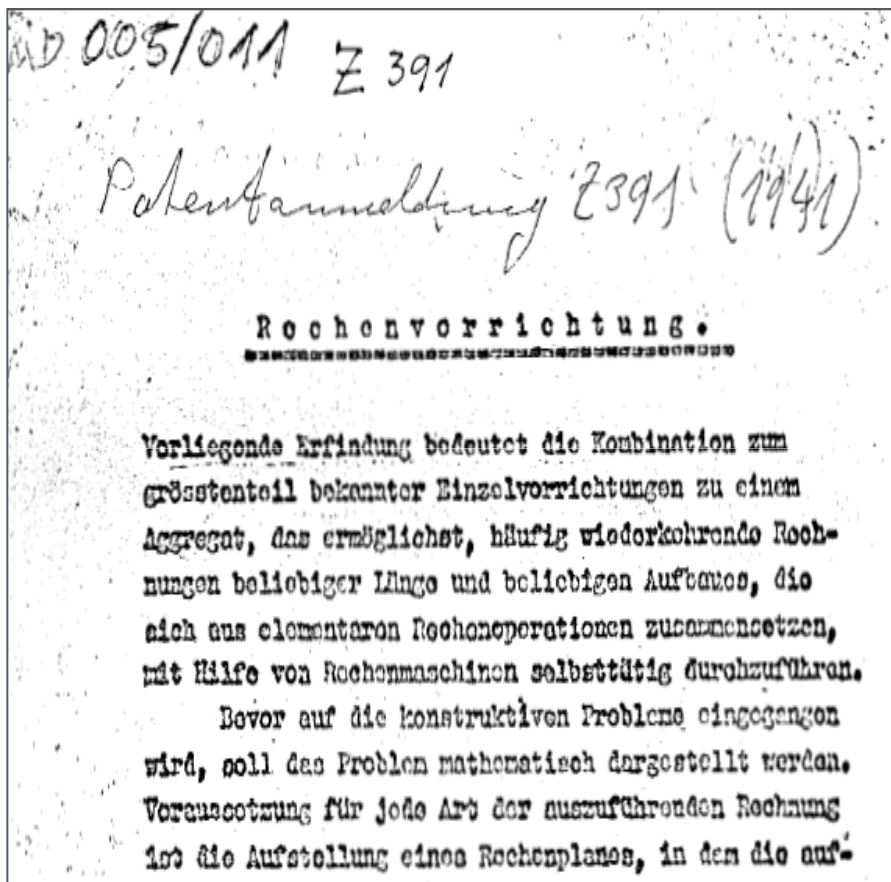

one of the first "software patent" applications
 submitted by Konrad Zuse on
 16.6.1941 at German Patent Office

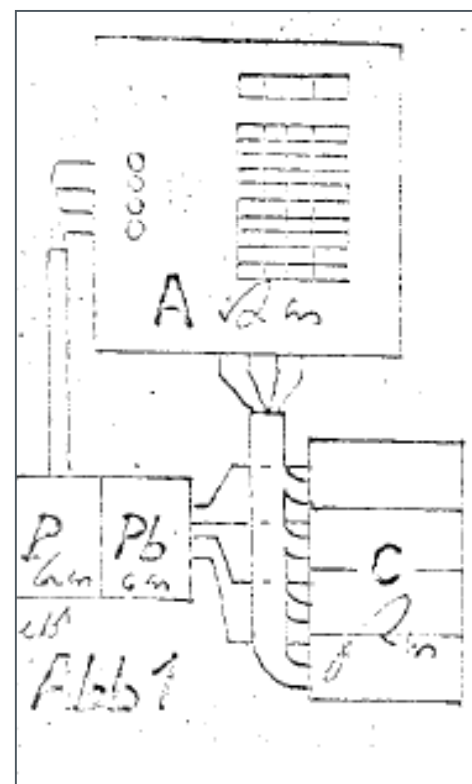

Konrad Zuse Internet Archive <http://www.zib.de/zuse>

Legal History I

- **1940s**: patent applications for first digital computers in Germany, USA, GB
- **1950s/1960s**: patent offices very often deny eligibility of functional features implemented by means of a computer program to patent law
- applicants interested in patents disguise software as hardware
- **end 1960s**: discussion on possibilities for the protection of computer programs
- **1970**: Patent Cooperation Treaty (PCT), list of excluded subject-matter in the regulations, Rule 39 search (Rule 67 examination)

"No International Searching Authority shall be required to search an international application if, and to the extent to which, its subject matter is any of the following:

....

(vi) computer programs to the extent that the International Searching Authority is not equipped to search prior art concerning such programs."

Legal History II

- **1973** European Patent Convention (EPC) was signed by 16 European states; EPC is partly based on PCT regulations
- **1977** EPC comes into force;
- **1970s** sui generis law for protection of computer programs under the guidance of WIPO is not successful;
- **1980** USA: amendment of copyright for the protection of computer programs and first positive decisions for patents for inventions comprising features implemented by means of a computer program at USPTO;
- **1980s** more liberal positions at many patent offices; traditionally patentable inventions should not be excluded just because they are implemented in software;

Legal History III

- **1990s** World Trade Organisation: TRIPS - protection of source code and object code by copyright; patents shall be available for inventions in all fields of technology;
- **EPC 2000**: Art. 52(1) "European patents shall be granted for any inventions, in all fields of technology,..."
- **2005** European Union: Directive on computer implemented inventions is rejected by European Parliament;
- **2008**
 - USA: In re Bilski decision of Federal Circuit
 - EPO: referral of the President to the Enlarged Board of Appeal; 2009: about 100 amicus curiae briefs from companies, institutions, ...
- **2010**
 - EPO G3/08: referral is not admissible; confirmation of legal practise at the EPO
 - USA In re Bilski: Supreme Court rejects decision of FC

European Patent Organisation - 38 member states

- The European Patent Convention (EPC)
 - provides the legal framework for the granting of European patents via a centralised procedure
 - establishes the European Patent Organisation
- 1973 – Diplomatic Conference in Munich ► signature of the EPC by 16 countries
- 1977 – Entry into force of the EPC in 7 countries

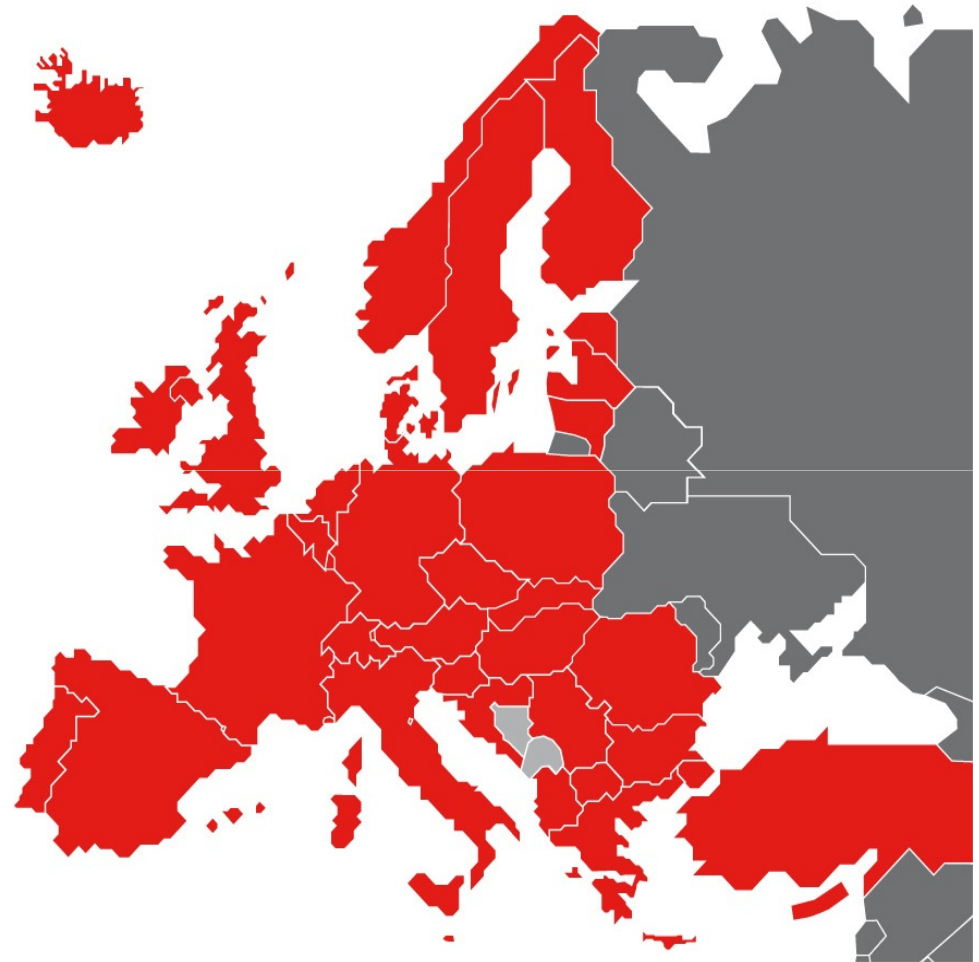

Autonomy



- Second largest intergovernmental institution in Europe
- Not an EU institution
- Self-financing, i.e. revenue from fees covers operating and capital expenditure

Structure of the European Patent Organisation

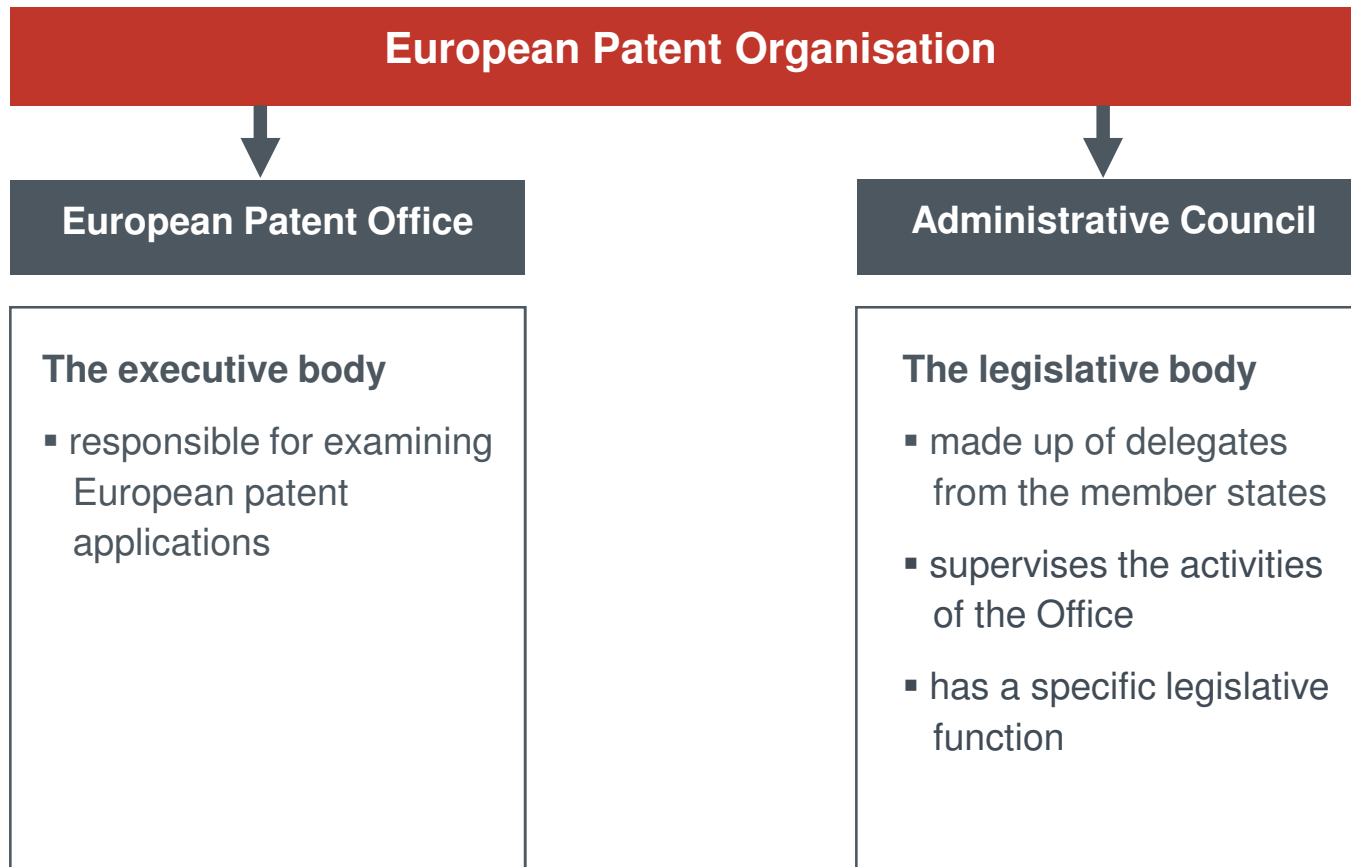

Technical fields with the most filings (2009)

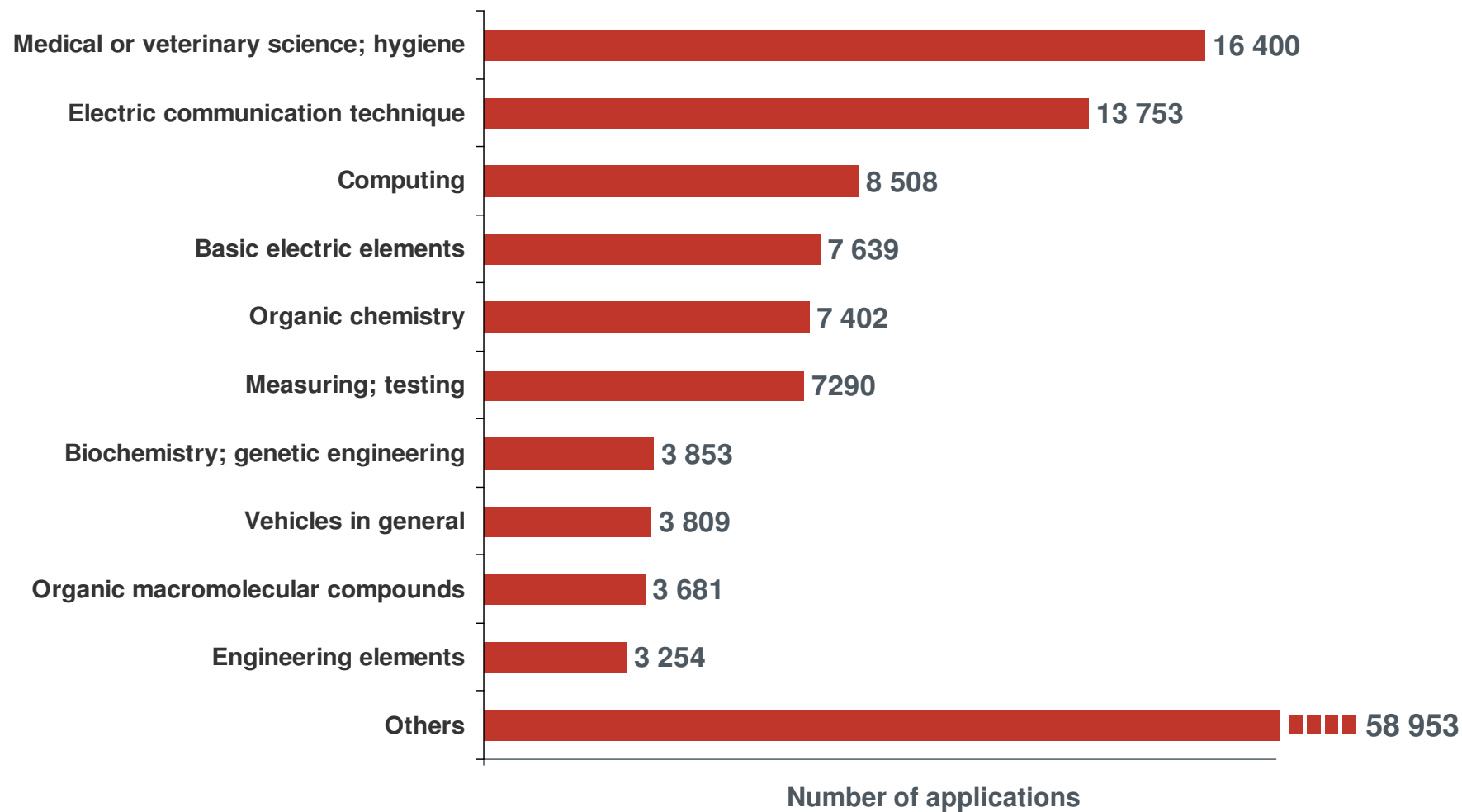

Applications by residence of applicant (2009)

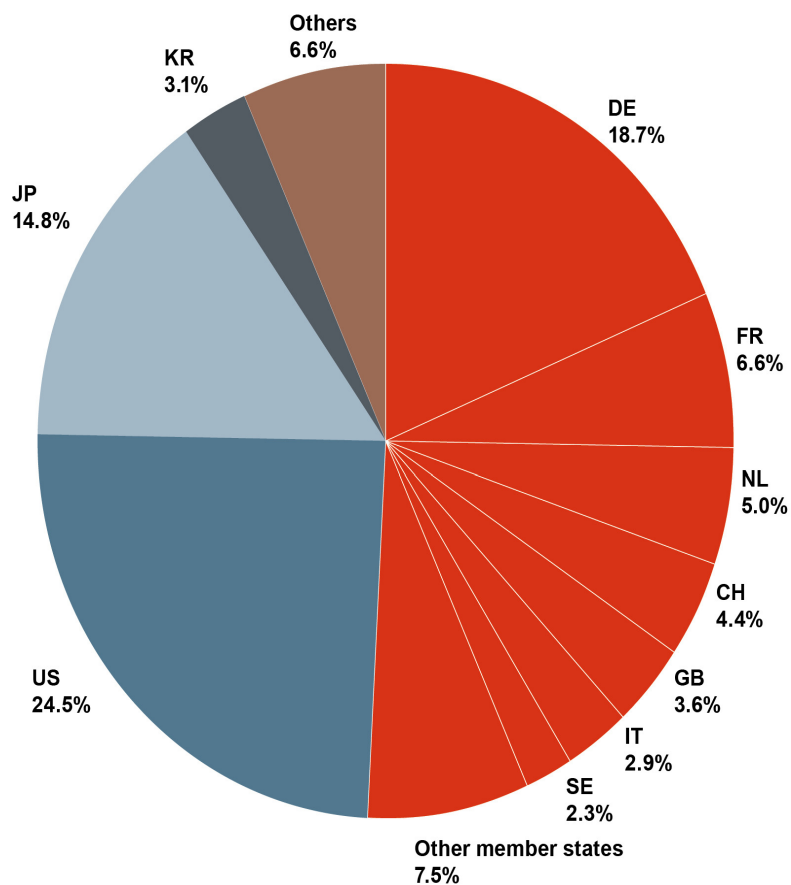

main applicants last three years

G06F9/40-9/50
(system software, middleware, ...)

IBM
Microsoft
Siemens
RIM
SAP

H04L29 networks

Telefonaktiebolaget Ericsson
Alcatel Lucent
Qualcomm
RIM
Nokia

Overview of European patent grant procedure (I)

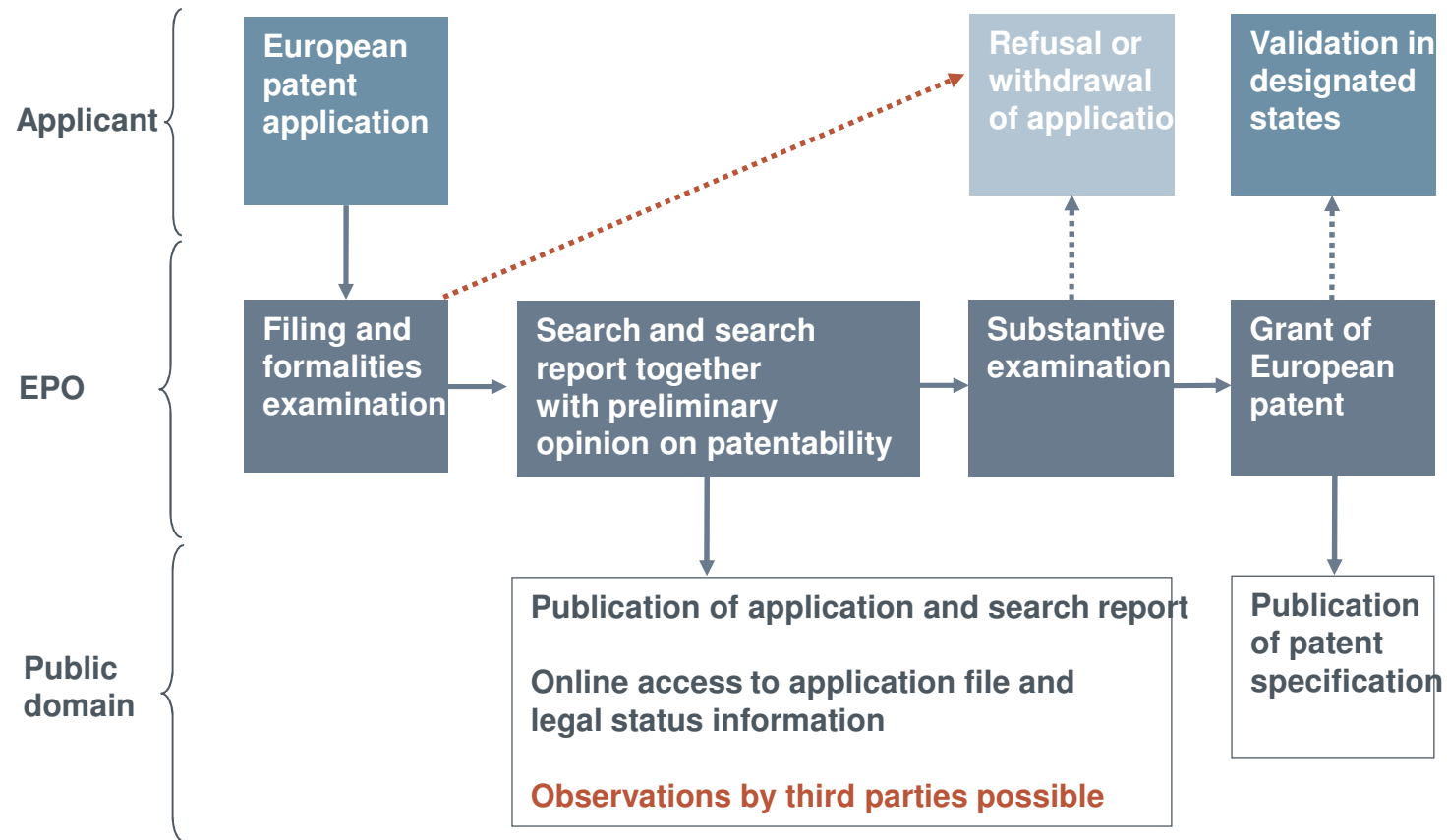

Overview of European patent grant procedure (II)



Final actions - grant, refusal, withdrawal

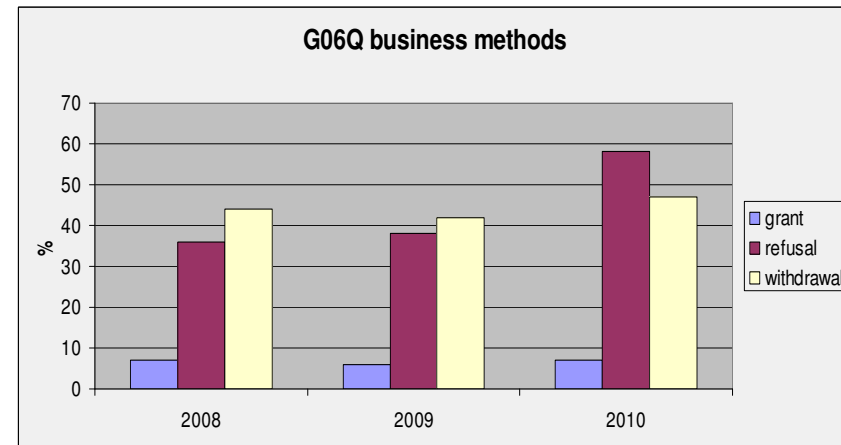
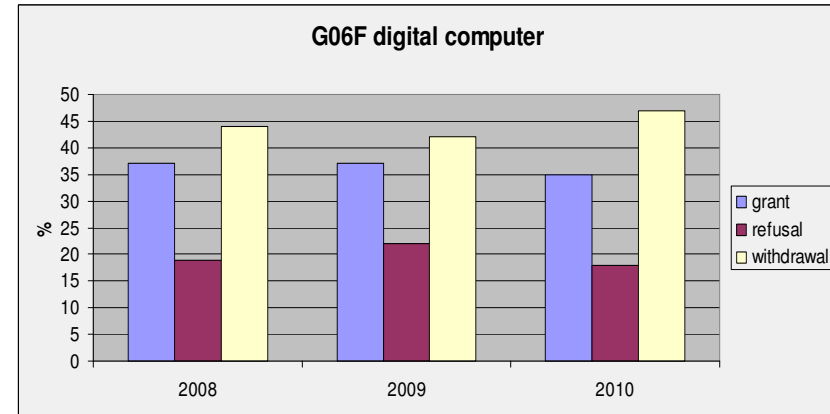
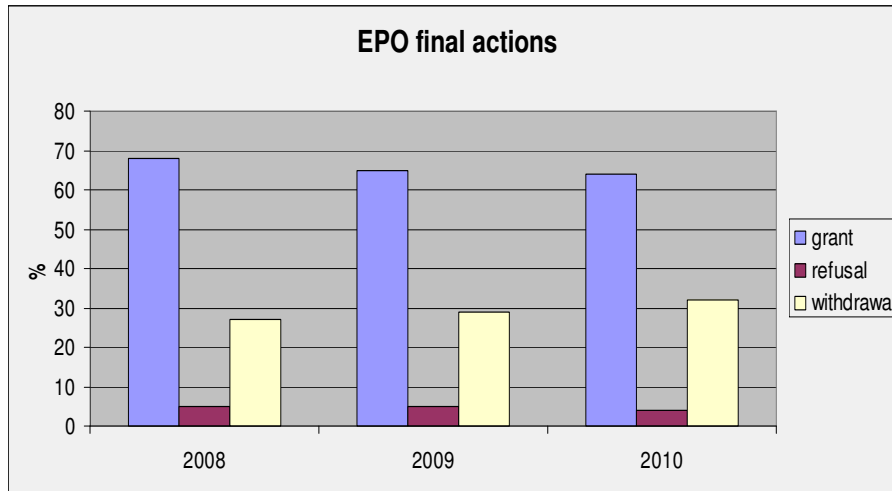

EPO

2008 granted patents: 59 809

2009 granted patents: 51 969

Layered model for a computer/computer network

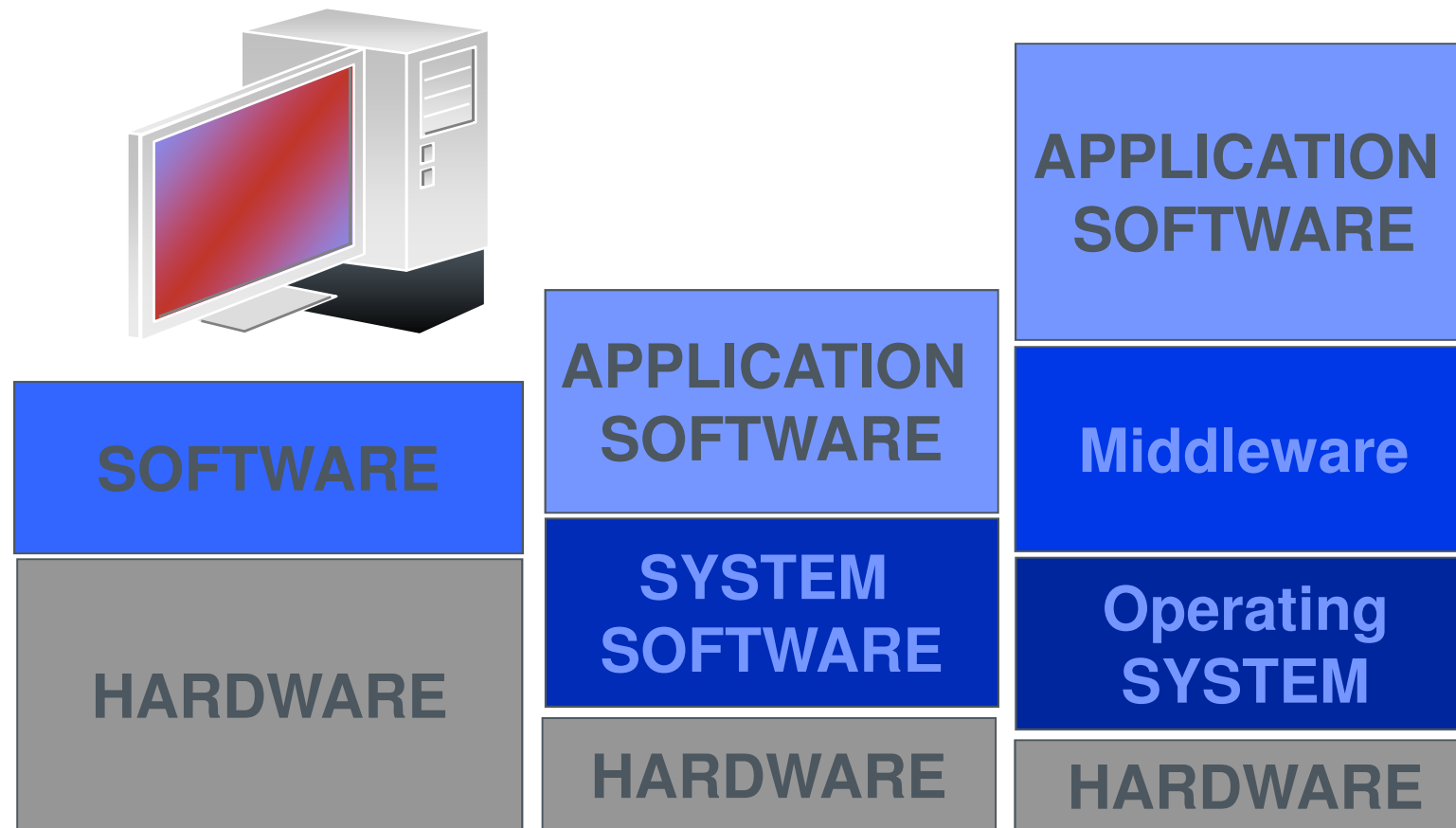

50s to 60s
mainframe

70s to 80s
microprocessor,
PC

S
...
Int
er

Distributed systems

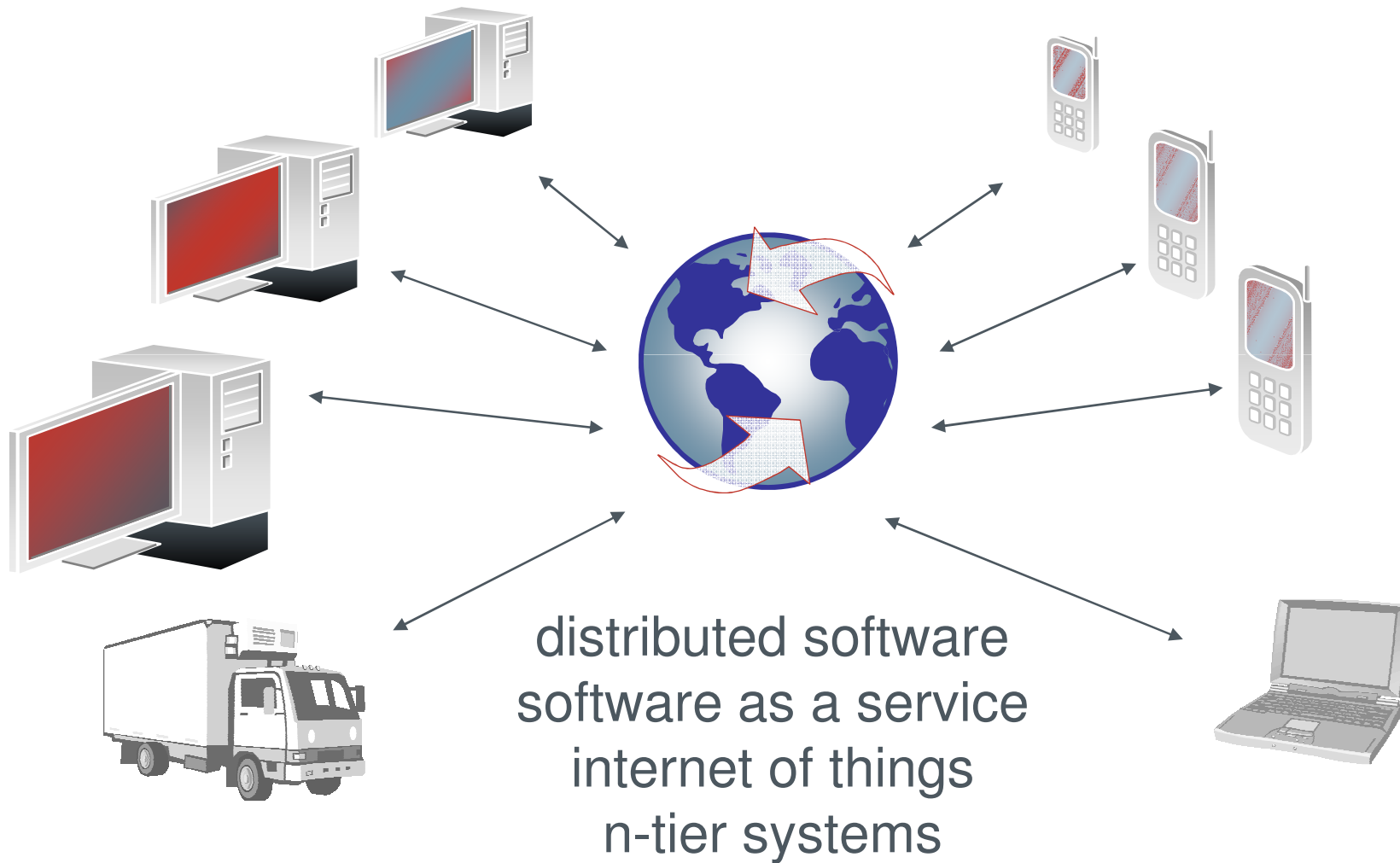

Digitization of information triggers new technologies

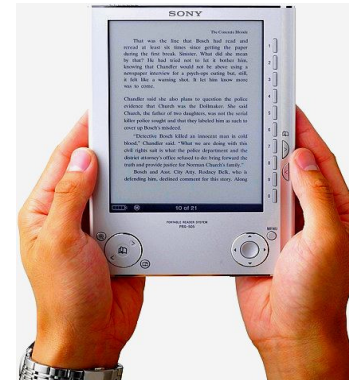

Basic Hardware/Software Analogy

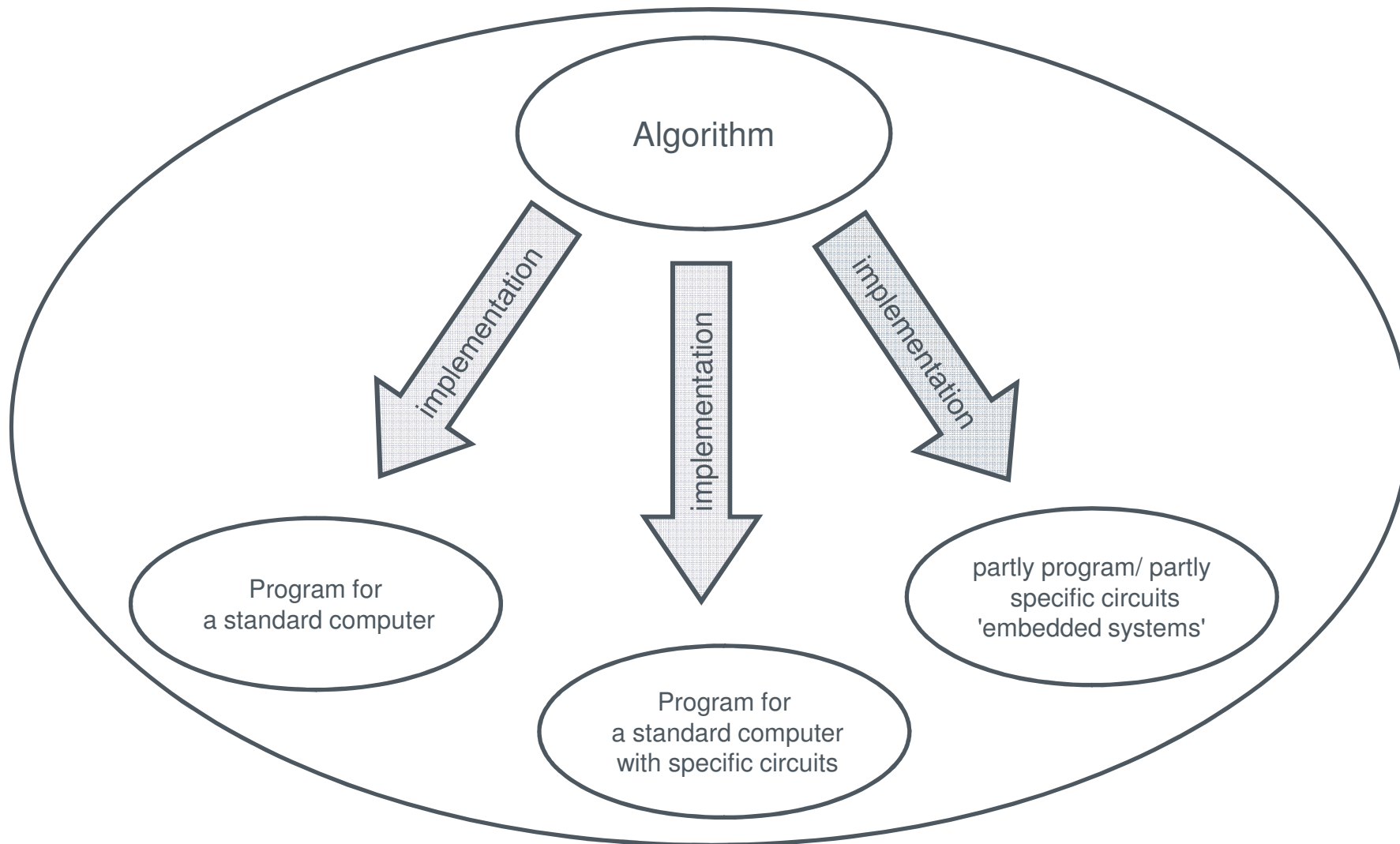

Basic steps of professional software development

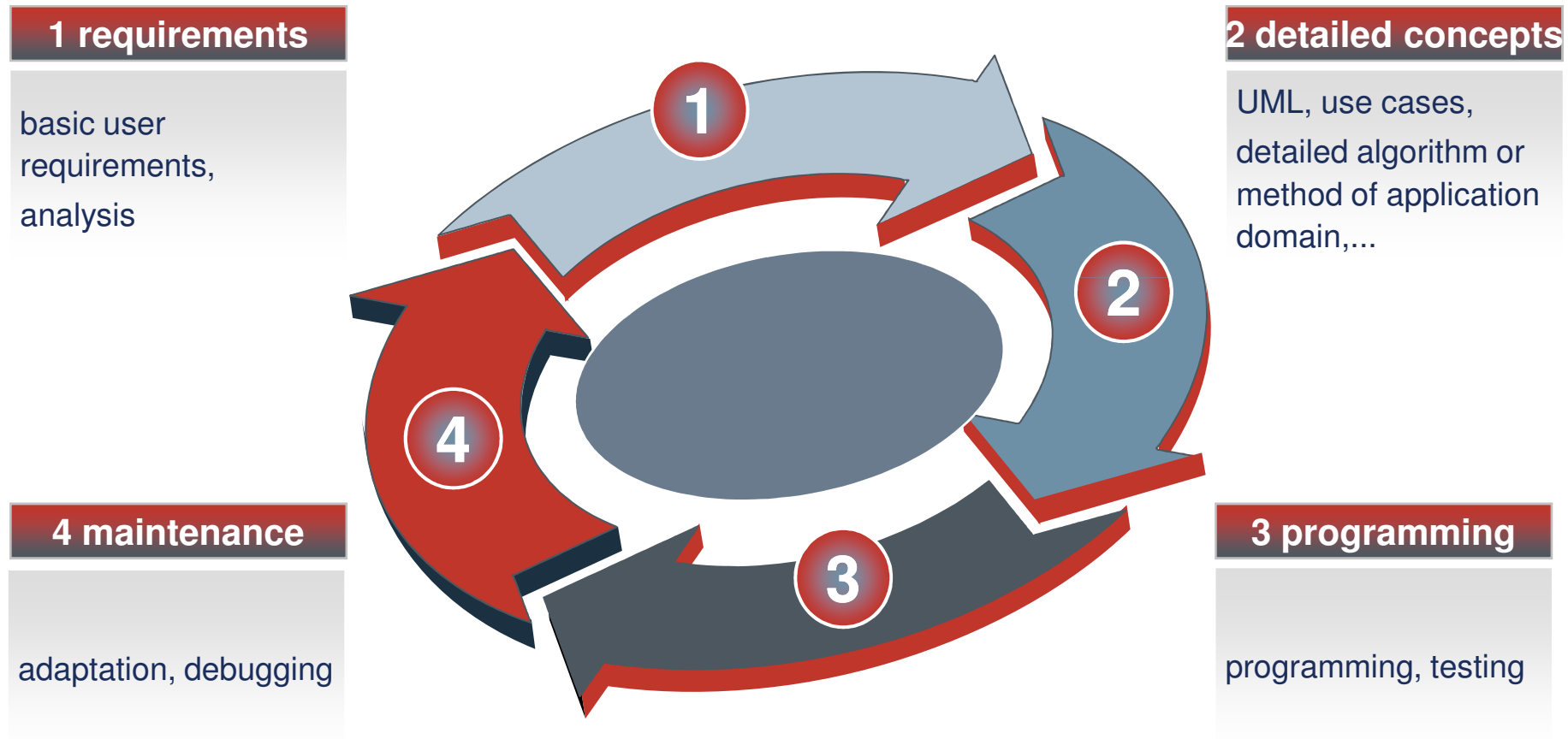

Classification of software

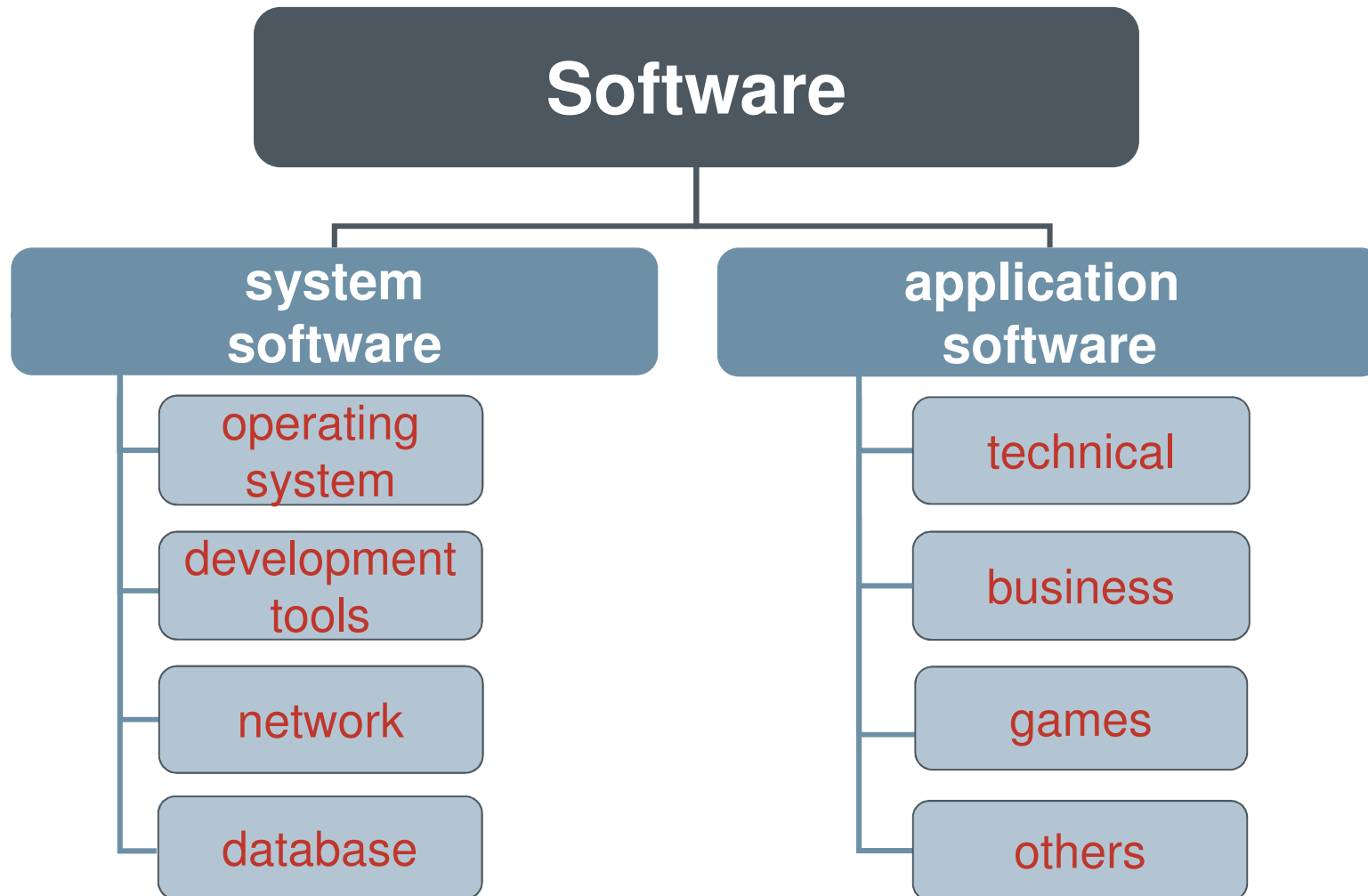

European Patent convention

Non-Inventions under Article 52 (2) and (3):

The following, in particular, shall **not** be regarded as inventions

- discoveries, scientific theories, mathematical methods
- aesthetic creations
- schemes, rules and methods for performing mental acts playing games or doing business
- **programs for computers**
- presentations of information

Is
often
forgotten!

Only to the extent to which a European patent application relates to such subject matter or activities **as such.**

Computer program ,as such‘

```
• #include <stdio.h>
  int main(void)
  {
    printf("hello world");
    return 0;
  }
```



Sourcecode

Objectcode



```
05 23 48 00 0A 1E 35 01 0F 19 35 01 19 1E 36 01
19 1E 36 01 04 00 00 00 60 80 3A 08 05 0A 81 00
05 0A 48 00 0A 1E 81 00 0A 1E 48 00 0A 1E 39 01
19 1E 39 01 1E 23 39 01 14 19 39 01 23 28 39 01
28 2D 39 01 1E 00 00 00 7C 80 3A 08 14 14 1B 00
14 14 4C 01 15 15 1B 00 15 15 4C 01 13 13 58 01
15 15 58 01 13 13 1B 00 13 13 4C 01 14 14 3E 01
14 14 3E 01 16 16 3E 01 16 16 3E 01 0A 00 00 00
AC 80 3A 08 14 1E B7 00 0A 14 B7 00 1E 23 B7 00
05 0A B7 00 14 1E 37 01 04 00 00 00 E4 80 3A 08
0A 0F 4A 00 05 0A 4A 00 0F 14 4A 00 0F 14 4A 00
0F 14 4A 00 14 00 00 00 00 81 3A 08 05 0A 81 00
05 0A 76 00 0A 1E 81 00 0A 1E 76 00 0A 1E 43 01
19 1E 43 01 1E 23 43 01 14 19 43 01 23 28 43 01
28 2D 43 01 1E 00 00 00 1C 81 3A 08 0F 0F 53 01
0F 0F 53 01 0F 0F 42 00 0E 0E 53 01 0E 0E 53 01
0E 0E 42 00 10 10 53 01 10 10 42 00 10 10 53 01
10 10 53 01 10 10 53 01 10 10 53 01 14 00 00 00
4C 81 3A 08 0F 0F 34 01 0F 0F 34 01 0F 0F 1B 00
0E 0E 34 01 0E 0E 34 01 0E 0E 1B 00 10 10 34 01
10 10 1B 00 10 10 34 01 10 10 E3 00 10 10 34 01
10 10 E3 00 14 00 00 00 84 81 3A 08 10 10 66 01
10 10 2A 01 11 11 66 01 0F 0F 66 01 0F 0F 2A 01
10 10 7C 01 10 10 2B 01 12 12 2B 01 11 11 7C 01
```





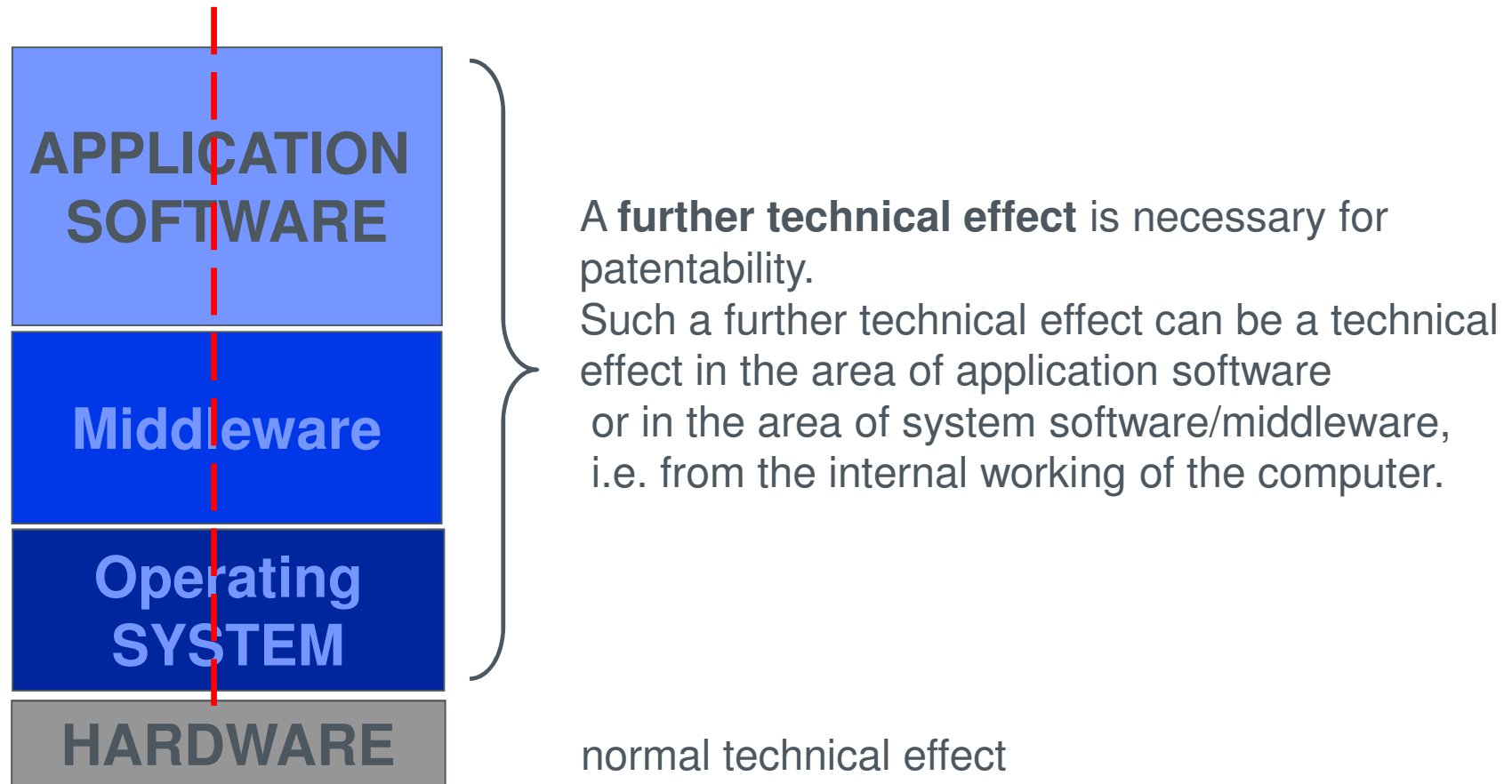



is not patentable !

Not all computer-implemented inventions are patentable







The **normal technical effect** (electric currents) is **not sufficient** to make inventions implemented by means of a computer program patentable.

Computer Program based on a 'technical algorithm'

technical application domain features		program features	patentable ? EPO	patentable ? US
technical	well-known method e.g. for a clock	normal implementation		
	temperature measurement	new memory access method		
	new and inventive method for blood analysis	normal implementation		
	chemical process	features for very fast real time data processing		

Computer Program based on a 'non-technical algorithm'

non-technical application domain features		program features	patentable ? EPO	patentable ? US
non-technical	photos	well-known implementation		
	well-known symphonies of Beethoven	new and inventive data compression		
	new and inventive pension calculation method	normal implementation		
	new and inventive stock trading method	new and inventive data transmission		

computer-implemented invention

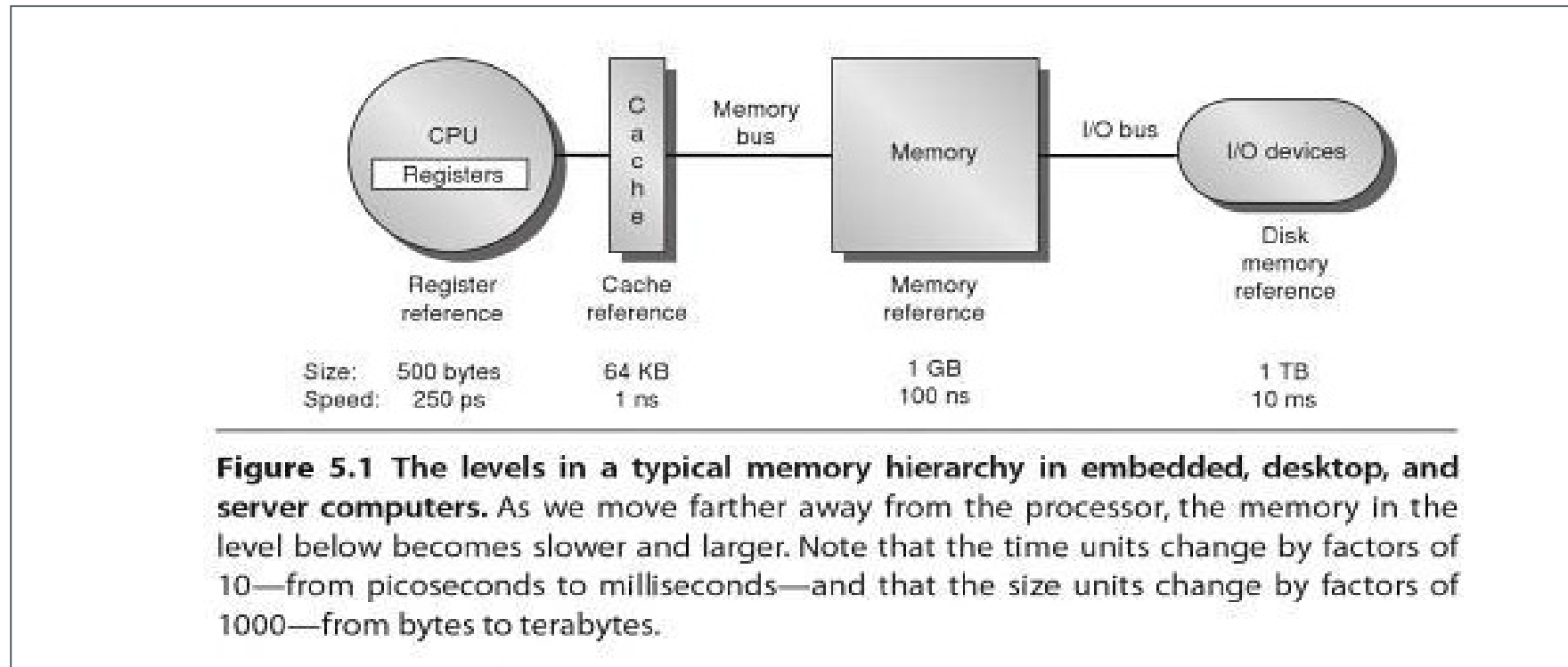

Hennessy, J.L. et al "Computer Architecture", 4th edition, 2007, 288

Further technical effect can result from the internal working of the computer:
 more efficient memory management

Software Patent? Lane recognition for a vehicle

Claims

- 40 1. Method for detecting lanes for a vehicle which is equipped with an adaptive cruise controller (12) with inter-vehicle distance control facility, the relative velocity (v_{rel}) of detected objects, the lateral offset (q) of the detected objects with respect to the longitudinal axis (3, 3a, 3b, 3c) of the vehicle and the velocity (v) of the driver's own vehicle being fed into the adaptive cruise controller (12) with inter-vehicle distance control facility by means of an object detection system (2), it being determined from the relative velocity of the objects (v_{rel}) and of the velocity (v) of the driver's own vehicle whether the object (5, 6, 7, 8) is an oncoming one, a stationary one or one which is moving in the same direction as the driver's own vehicle, **characterized in that** the number of existing lanes and the lane which is being travelled on by the driver's own vehicle at that particular time are determined in conjunction with the calculated lateral offset (q) of the object with respect to the longitudinal axis (3, 3a, 3b, 3c) of the vehicle, and the detection range (9, 10, 11) of the object detection system (2) is changed as a function of the detected lane.

The claim does not comprise any details concerning the computational implementation but the method (algorithm) which is basis for the implementation by means of a computer program. The description mentions a microprocessor.

EP-B1- 1671196

Not patentable - legal practise

- source code, object code;
- organisational rules for software development;
- programming languages;
- an abstract data structure for a computer program (array, record, ...);
- object-oriented models of real systems;
- pure aesthetic features of GUIs, computer games, web pages;
- theoretical concepts of computer science (e.g. Chomsky Hierarchy)
- ...

Advantages and disadvantages of patenting

Advantages

- exclusivity enables investment and higher returns on investment
- strong, enforceable legal right →
- makes invention tradable (licensing)

Disadvantages

- reveals invention to competitors (generally 18 months after first filing)
- however, not in every country
- can be expensive
- procedure may be long (up to 4 - 5 years)

Cost of a European patent up to grant

4 types of cost:

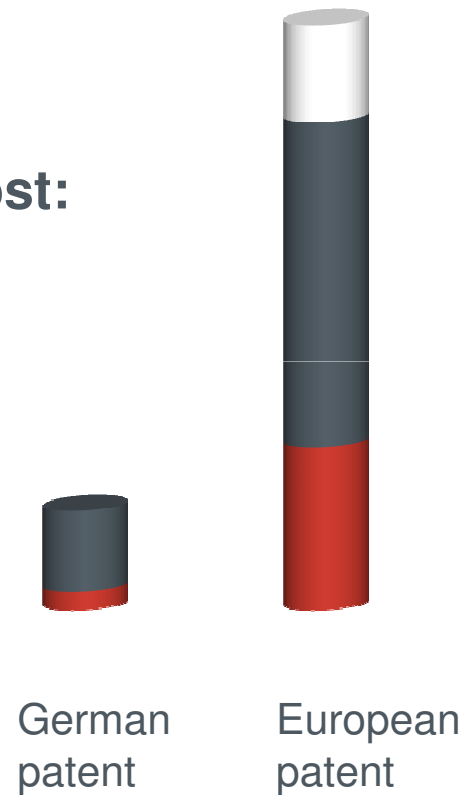

translations*:
3000 EUR

attorney fees*:
10000 EUR

patent office fees*:
5000 EUR



renewal fees:
from 3rd year on,
max. 20 years

* estimated cost
Actual cost depends very much on the specifics of the individual case.

100 EUR ~ 127 USD

What happens if I do not patent my innovative products or processes?

Somebody else might patent it!

Competitors will take advantage of your invention!

Possibilities of licensing, selling or transferring technology will be severely hampered!

Alternatives to patenting

Information disclosure ("defensive" publishing)

- cheap
- prevents others from patenting the same invention

- does not offer exclusivity
- reveals the invention to competitors

Secrecy (creating a trade secret)

- cheap (but there is the cost of maintaining secrecy)
- does not reveal the invention

- no protection against reverse-engineering/ duplication of invention
- difficult to enforce
- "secrets" often leak quite fast

Do nothing

- no effort required

- does not offer exclusivity
- competitors will often learn details

Most commonly made IP mistakes

- Believing that IP protection is universal
- Assuming that laws and procedures for the protection of IP rights are the same worldwide
- Not considering the regional or international protection systems
- Applying too late for IP protection abroad
- Disclosing information too early, e.g. at conferences or without a confidentiality agreement
- Infringing the IP rights of others
- Not defining issues of ownership of IP rights when outsourcing manufacturing

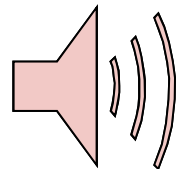

SEEK LEGAL ADVICE!

What is patent information?

- patent documents are public information
- they disclose how inventions work
- access to the information is (often) free of charge

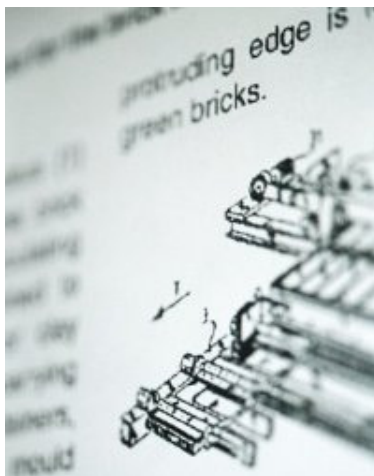
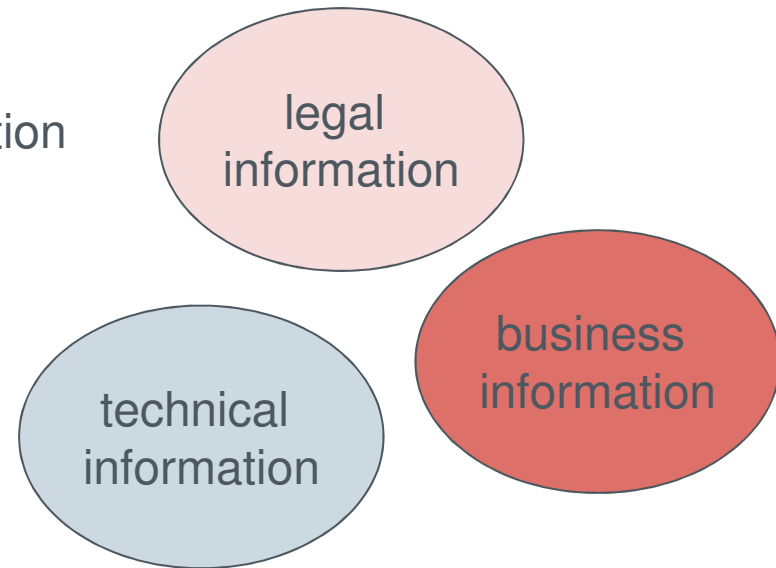

Four good reasons to use patent information

1. find out what already exists and build on it
2. keep track of who's doing what
3. avoid infringing other people's patent rights
4. improve the quality of your patent application

Technical Information

Example: EPO esp@cenet:

- worldwide patent database
- search 60 million patents documents online
- one of the world's biggest technology databases
- data from 1836 to today
- free of charge

technical
information

esp@cenet

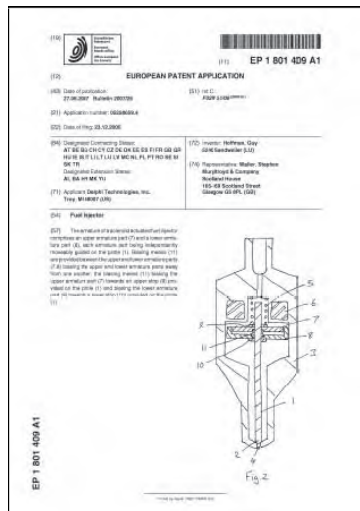

You can use esp@cenet to:

- watch new technologies emerge
- find solutions to your technical problems
- discover what your competitors are developing
- find business partners

Legal information



EPO: Register Plus = online file inspection

- gives access to all the public documents in the file of a European patent application
- procedural information on all European patent applications
- alert service
- free of charge

legal
information

What can Register Plus do for you?

- find out what stage in the procedure a European patent application has reached
- see if a European patent application has been granted, or will be granted soon
- check whether any oppositions to a European patent have been filed
- read the correspondence between the EPO and the patent applicant/attorney.

Business information

Evaluating patents and patent portfolios:

▪ **Licensing:**

knowing the value of your patents puts you in a better position to negotiate licensing agreements.

▪ **Investment decisions:**

a detailed analysis of the patents held by a company may be a critical factor for investors in the company, or for obtaining public funding.

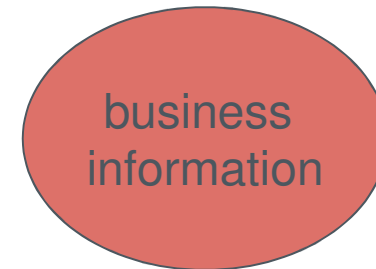

The EPO's patent evaluation software: IPscore

- examine your company's patent portfolio
 - analyse the value of individual patents
 - align your company's patent strategy with your overall business strategy
 - make the best use of patents as a business tool
 - identify opportunities and risks
- free of charge:
<http://www.epo.org/ipscore.html>

Patent information from East Asia at the EPO

- More than half the patent applications filed worldwide every year are written in Japanese, Chinese or Korean.
- Asia Helpdesk:
staffed with experts in the Japanese, Chinese and Korean patent systems who can answer your queries.
- Search Services
- Translation Services

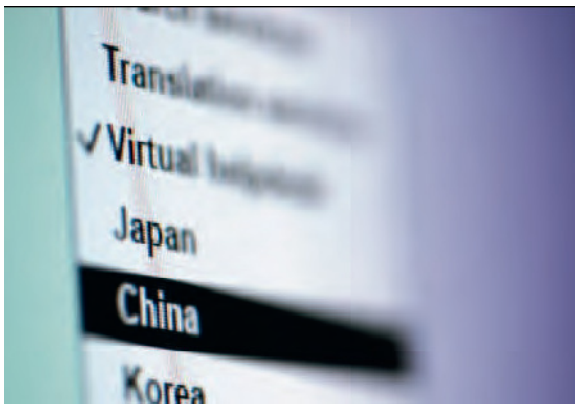
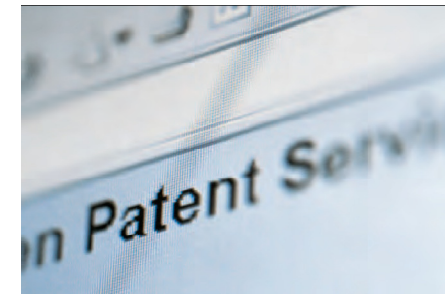

Virtual helpdesk:

- gives answers to FAQ on industrial property in Japan, India, China and Korea
- provides background information on filing trends, the granting procedures, the numbering systems and terminology of patents in Asia.

Further Information (download)



WIPO:
 Inventing the future -
 An introduction to
 patents for SMEs

WIPO: Secrets of
 Intellectual Property:
 A Guide for Small
 and Medium-sized
 Exporters

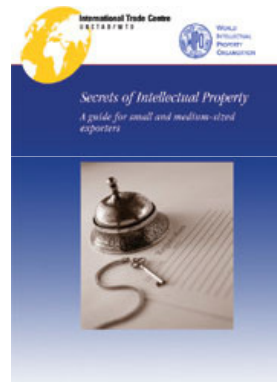

EPO: Guide for beginners
 to the esp@cenet service.
 In six easy steps it shows
 newcomers to esp@cenet
 how to perform simple
 searches.



EPO:
 Patent information:
 Adding certainty to
 your patent, legal and
 business decisions

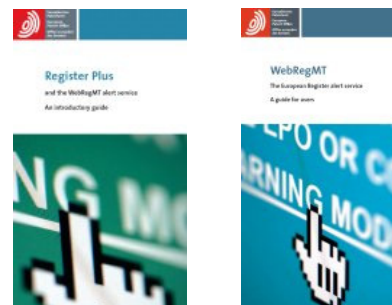

EPO: These guides explain
 how to use online European
 patent register, online public
 file inspection, alert service.

Further information (download)



Patent teaching kit

Designed for use by university lecturers, it contains presentations, teachers' notes, background information, real-world examples and case studies - everything lecturers need to provide students with a comprehensive introduction to the patent system, including information on how to file patent applications and search for existing patents.

free of charge (download or hard copy)

<http://www.epo.org/patents/learning/teaching.html>

core modules:

- an introduction for students of science, engineering and business administration
- an introduction for law students

sub-modules:

- searching for existing patents - how to use the esp@cenet database
- the use of patents by a university spin off
- understanding patent claims: 7 case studies

Summary

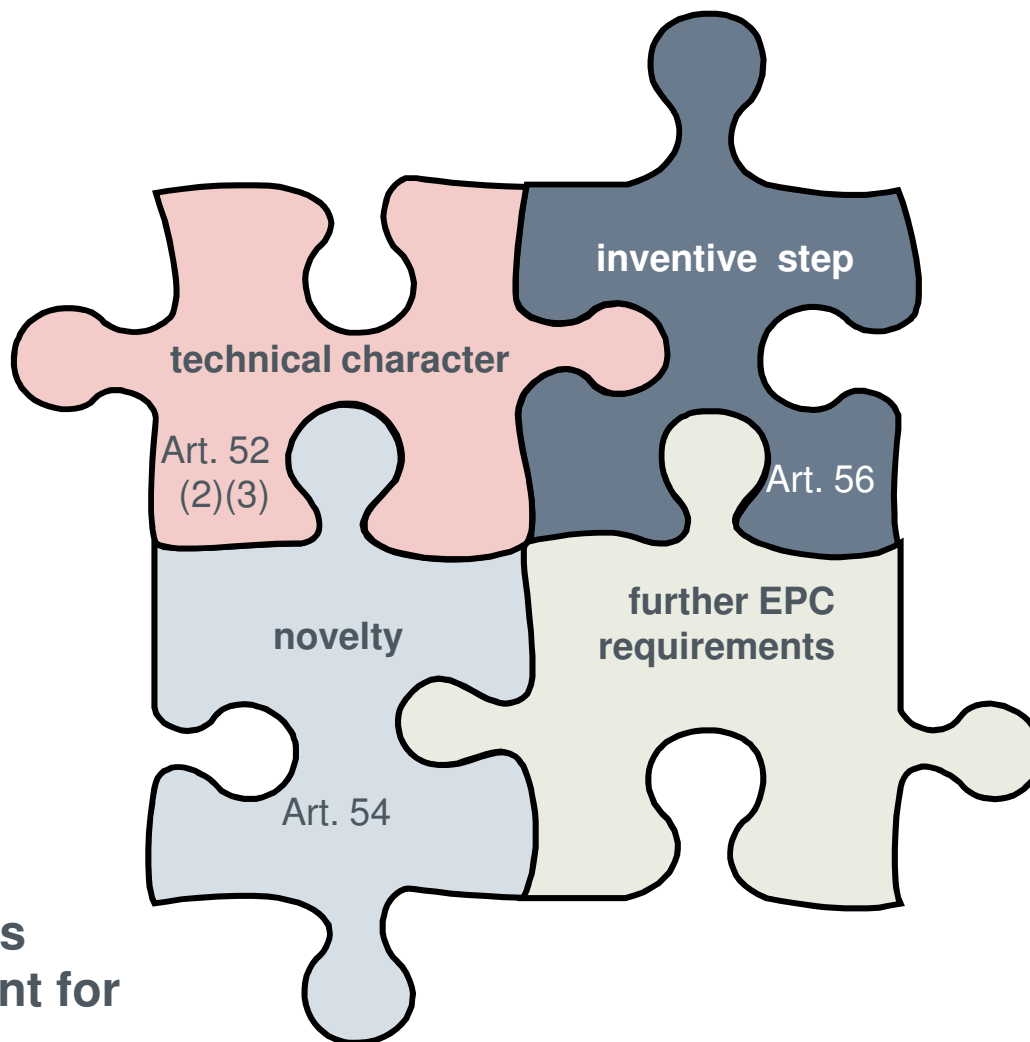

**Basic components
for the grant of a patent for
an invention**

THANK YOU !

Sabine Kruspig
skruspig@epo.org