

The Challenge of SSME – Services Science, Management and Engineering

Liba Svobodova
svo@zurich.ibm.com

IBM Research Worldwide



Outline

- **The Rise of the Service Economy**
- **Services Science, Management, and Engineering (SSME)**
- **SSME Initiatives and Programs Around the World**
- **SSME Challenges**

Key Trends

- **All national economies are shifting to services**
 - Major industrialized nations are >70% services, developing nations are close behind
 - Globalization and off-shoring are changing the services market
- **Service innovation recognized as key for the economic growth and competitiveness**
 - Governments and industry are increasing investments in services research
- **New education and research programs are emerging to address the needs of services business**

ICT plays a major role in services innovation and realization

The Rise of the Service Economy

Source: 2004 IBM Study based on national labor data

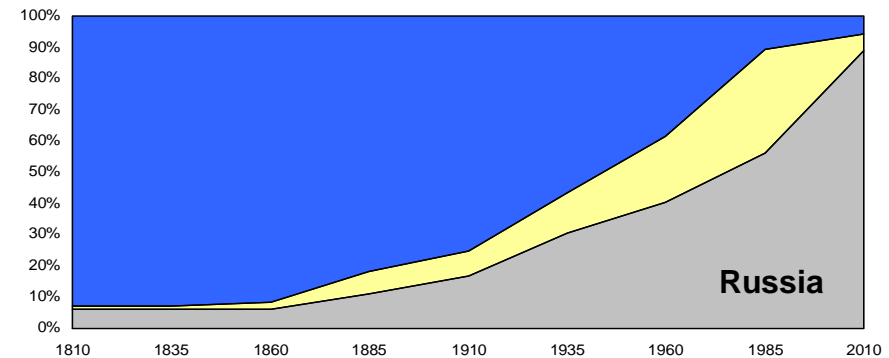
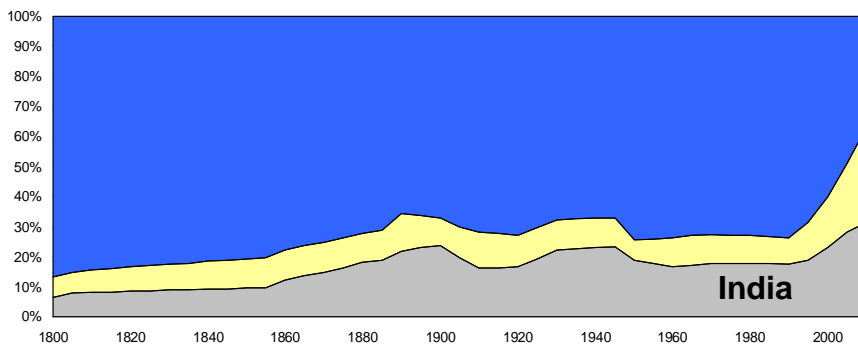
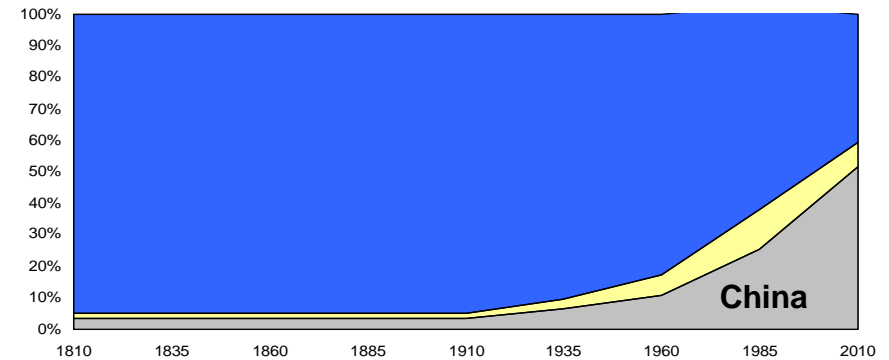
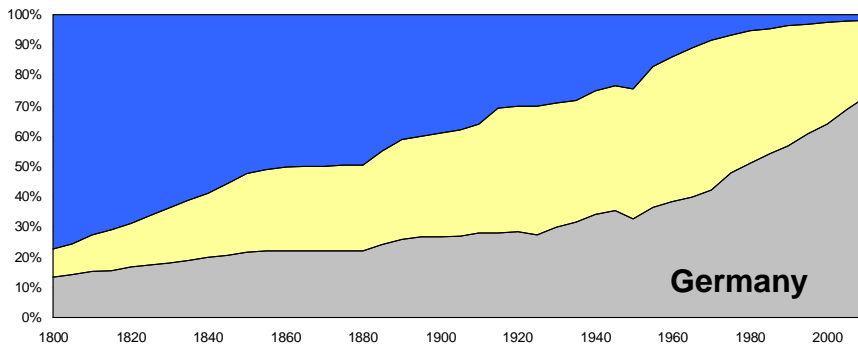
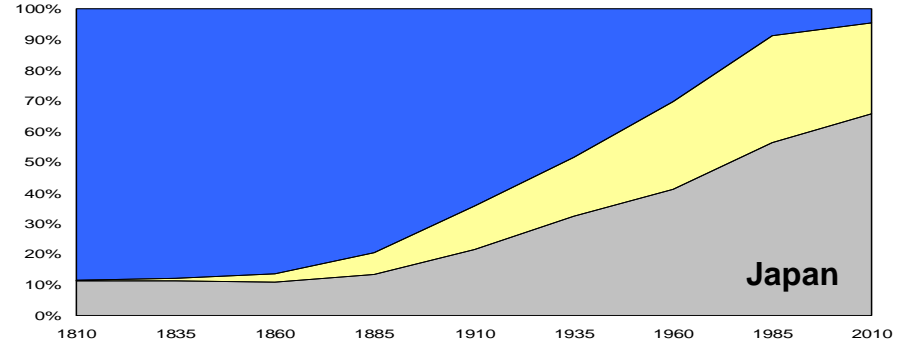
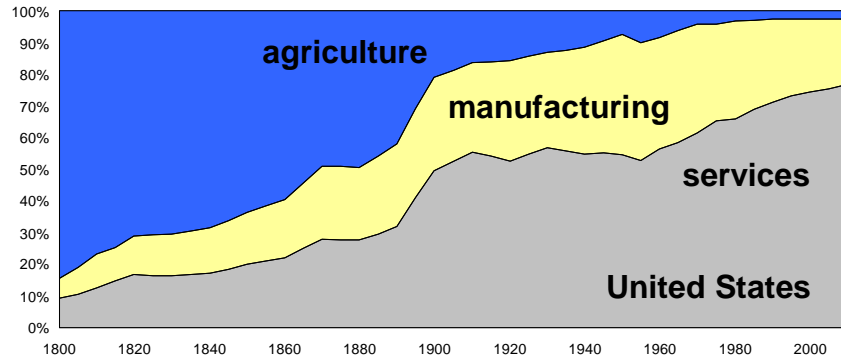

Understanding the Relative Growth of the Service Economy

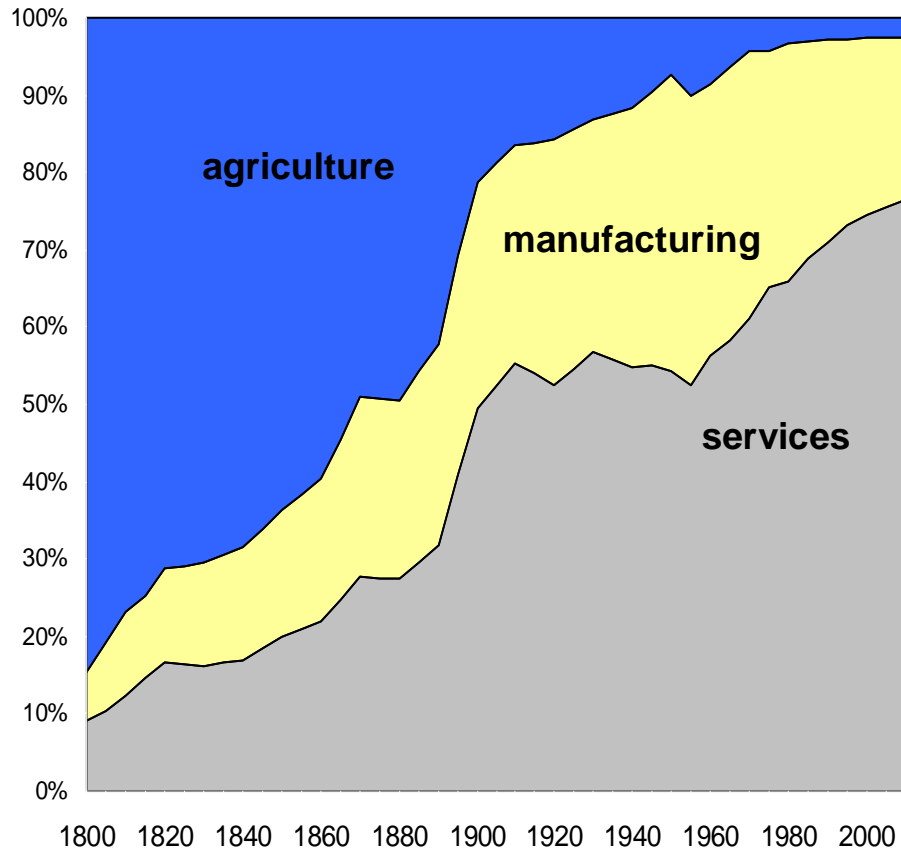

Bryson et alli, *Service Worlds: People, Organizations, Technologies*

- **Imprecise definition of Services**
- **Data collection artifacts**
- **Increase in demand for services as income levels rise**
- **Business services outsourcing**

- **High productivity gains in agriculture and manufacturing**
 - Reducing workforce costs
 - Automation of production processes
 - Economies of scale
 - Innovation in products and processes

How does this apply to Services ?

Professional & Business Services

- Service jobs are increasingly the **high skill** knowledge worker jobs – especially in business and information services
- Growing demand for new generation of innovators with deep knowledge of service related disciplines



Projected US Service Employment Growth, 2004 - 2014

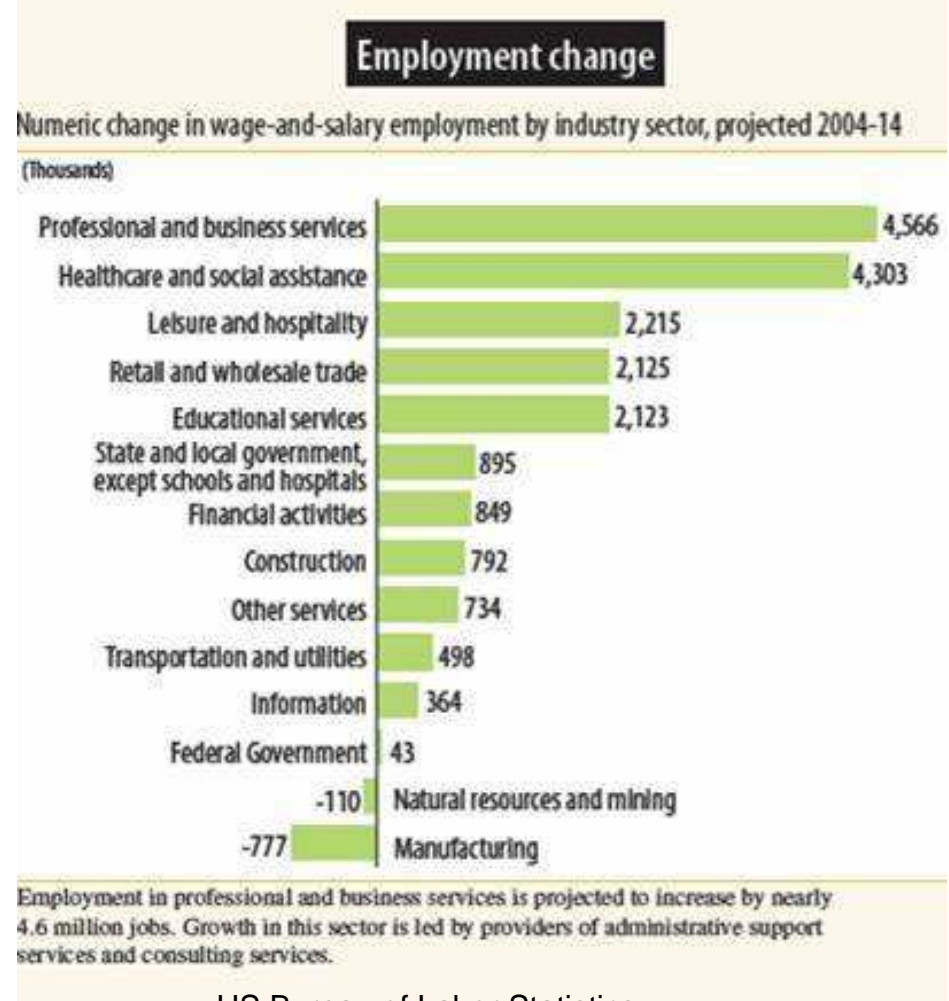

US Bureau of Labor Statistics.

<http://www.bls.gov/opub/ooq/2005/winter/art03.pdf>



**SSME: Services Science, Management and
Engineering** (*and Design – SSMED*)

What is SSME?

- SSME is an interdisciplinary application of science, management, and engineering disciplines to services
- SSME addresses *service systems*, their design, evolution, processes and data, to create value, increase productivity, improve quality, control risk, innovate for growth and operate in dynamic environments
- SSME is an emerging academic curriculum and research area

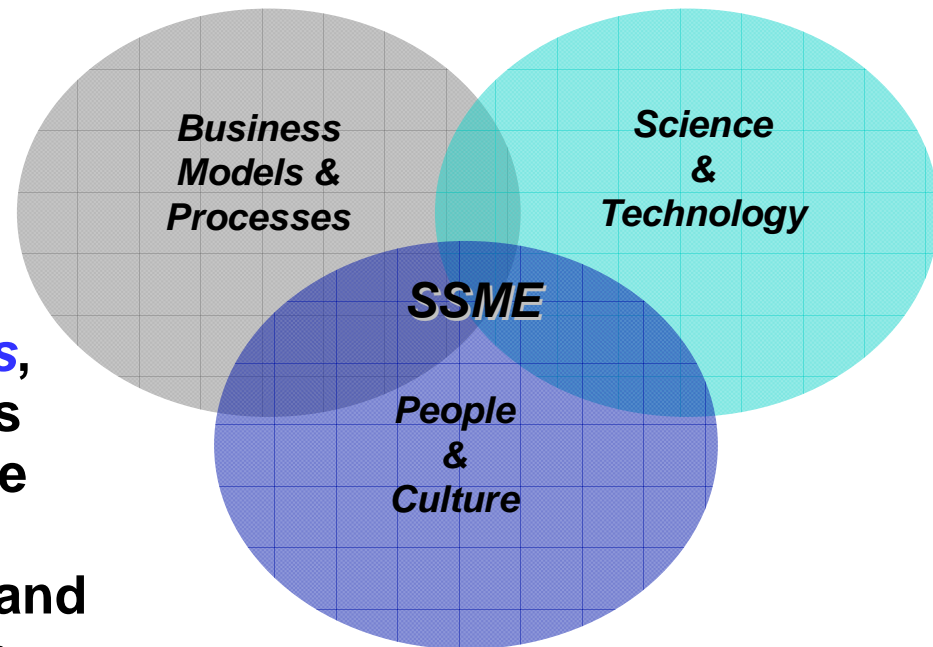

More than technology innovation, services innovation is interdisciplinary (business, organizational and technology innovation)

Service scientists need to be both broad and deep



T-shaped people – They speak the language of many disciplines, and are deep in at least one area

Open SSME Website – ibm.com/university/ssme

Country/region [select] | Terms of use

IBM Academic Initiative | Search

Home | Products | Services & solutions | Support & downloads | My account

Academic Initiative > Skills for the 21st century >

Services Science, Management, and Engineering

Getting Started | Learn | Teach | Connect

Course materials
Case studies

What is SSME?

Services Science, Management and Engineering (SSME) is a new multi-disciplinary research and academic effort that integrates aspects of established fields such as computer science, operations research, engineering, management sciences, business strategy, social and cognitive sciences, and legal sciences.

Global markets are shifting from agriculture and manufacturing to service-based economies and the U.S. Bureau of Labor Statistics employment projections forecast that employment growth will continue to be concentrated in the service-providing sector of the economy. With major industrialized nations now more than 75% services and developing nations close behind, governments and industry need talent and skills in the services arena.

Services design, development, marketing and delivery all require methodologies and techniques to make services businesses more efficient and scalable. Both depth and breadth is needed in technology, business, and organizational studies, even at the undergraduate level.

The goal of the SSME discipline is to make productivity, quality, sustainability, learning rates and innovation rates more predictable across the service sector. We hope the resources on this site help you to better

SYSTEMS JOURNAL

IBM Wakes Up to India's Skills

What is "Service Science"?

The New Science



SSME Initiatives and Programs

Examples from USA and Europe

Growing interest and engagement in SSME worldwide

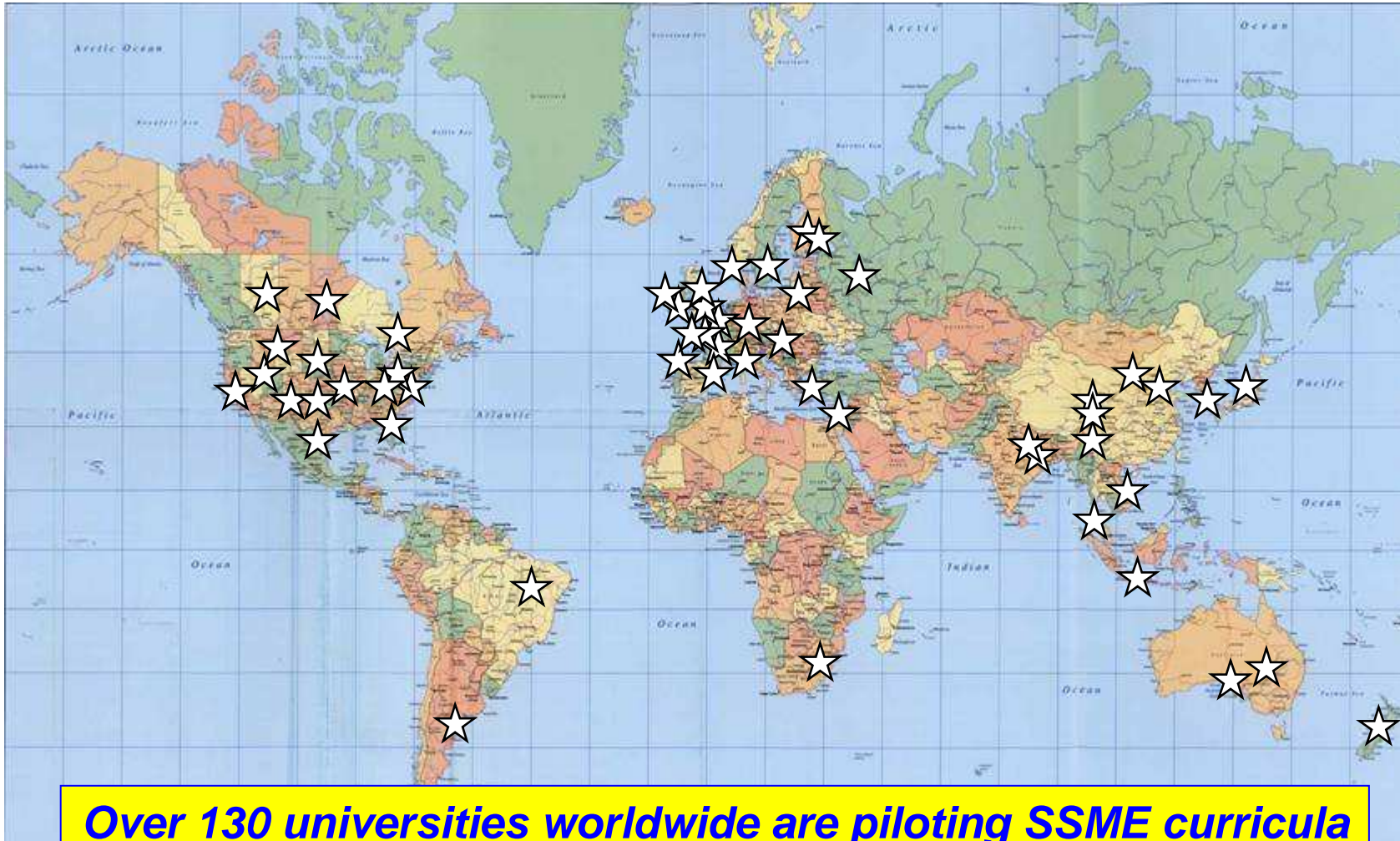

Over 130 universities worldwide are piloting SSME curricula and programs

SSME at UC Berkeley, School of Information

<http://isd.ischool.berkeley.edu/> (<http://ssme.berkeley.edu/>)



Information & Service Design

About People Areas Publications Courses Partners Projects Events News

Information and Service Design

The *Information and Service Design (ISD)* program was established at UC Berkeley's School of Information in 2007 to provide a focus for teaching and research on the skills and concepts required by a service-led and information-powered economy. Our major activities include:

- The ISD program runs a Clinic where students gain hands on experience in information service design and consultant practice.
- The ISD program has research initiatives in mobile and location-based services, and systems that facilitate collaboration and knowledge sharing among professional communities.
- The ISD program works to advance service research by hosting a lecture series, organizing an annual symposium, and by hosting visiting scholars. The ISD program also encourages collaboration with other academic, nonprofit, and commercial partners.

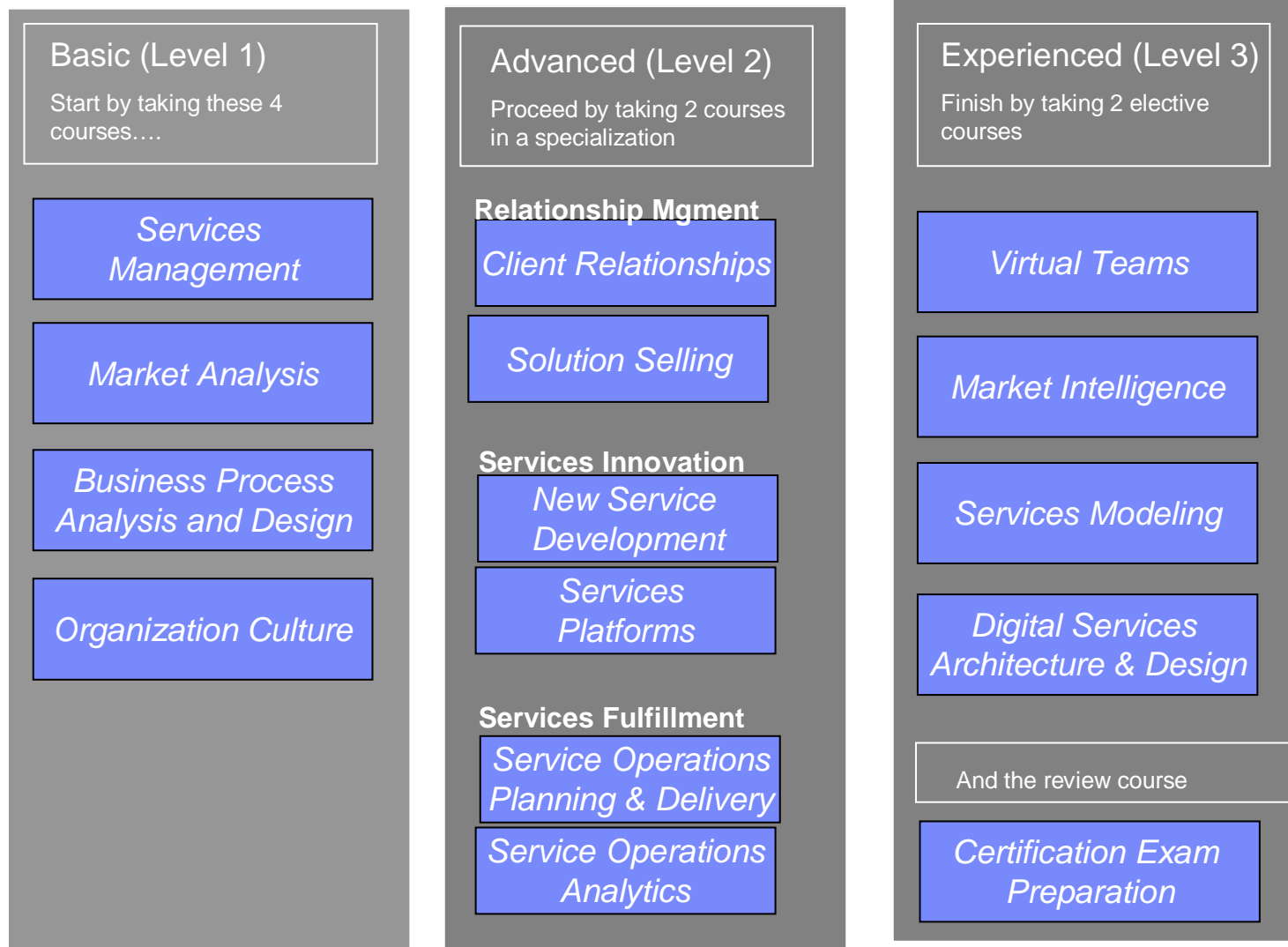

Image credit: Miss Karen, via Flickr

- **Course: Information System and Service Design: Strategy, Models, and Methods** <http://courses.ischool.berkeley.edu/i290-1/f08/ISD-Fall2008-Syllabus.html>
- **Paper: Designing a service science discipline with discipline, R.J. Glushko**
<http://www.research.ibm.com/journal/sj/471/glushko.pdf>

SSME at North Carolina State University

<http://www.ssme.ncsu.edu/>



Michigan Technological University, College of Engineering

Service Systems Engineering - <http://www.sse.mtu.edu/>

- NSF funding to develop new undergraduate curriculum
 - aimed at satisfying the engineering needs of the service economy

- Eight new courses
 - World of Service Systems Engineering
 - Service System Design and Dynamics
 - Analysis and Design of Web-based Services
 - Human Influences on Service Systems
 - Service System Operations
 - Optimization and Adaptive Decision Making
 - Project Planning and Management for Engineers
 - Managing Risk

America COMPETES Act

America Creating Opportunities to Meaningfully Promote Excellence in Technology, Education, and Science Act

- President Bush signed this act into law on August 9th, 2007
- **SEC. 1106. STUDY OF SERVICE SCIENCE.**
 - (a) *Sense of Congress- It is the sense of Congress that, in order to strengthen the competitiveness of United States enterprises and institutions and to prepare the people of the United States for high-wage, high-skill employment, the Federal Government should **better understand and respond strategically to the emerging management and learning discipline known as service science.***
 -
 - (d) *Service Science Defined- In this section, the term `service science' means curricula, training, and research programs that are designed to teach individuals to apply scientific, engineering, and management disciplines that integrate elements of computer science, operations research, industrial engineering, business strategy, management sciences, and social and legal sciences, in order to encourage innovation in how organizations create value for customers and shareholders that could not be achieved through such disciplines working in isolation.*

SRII - Service Research and Innovation Initiative → SRIC - Service Research and Innovation Community

<http://forums.thesrii.org/>

- SRII announced March 2007
- Consortium of technology companies, government agencies and universities dedicated to fostering advancements in service research
- SRIC - Interest areas
 - Customers & Markets
 - Service Operations and Excellence
 - Service Business Strategy and Governance
 - Government and University Programs

Founding partners



SSME in Europe

- **Many universities across Europe are embracing SSME**
 - Multidisciplinary cross-school or cross-faculty programs are still rare
 - Collaboration / student exchange programs among universities starting
- **Industry is paying increasing attention to innovation in services**
 - Strong focus on “servitization” – shifts on the products to services scale
 - Country-level networks / consortia including academia focusing on service innovation
 - EIRMA (European Industrial Research Management Association) conducted several round tables on service innovation
- **Increasing awareness and support in government agencies**
 - Approval of new curricula and research funding
- **EU programs address research and innovation in Services**
 - Networked European Software and Services Initiative (NESSI)
 - European Innovation Platform for Knowledge Intensive Services (initiative of Europe INNOVA)
- **White paper from Cambridge SSME symposium**
 - Framework and recommendations for developing SSME

White Paper: Succeeding through Service Innovation

A service perspective for education, research, business and government

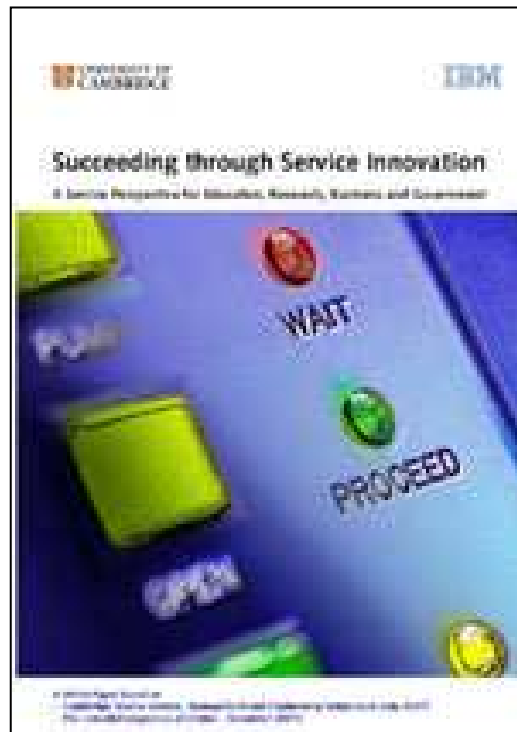

White paper based on the Cambridge Service Science, Management and Engineering Symposium (University of Cambridge, July 2007) and the following consultation process

115 people from 20 countries contributed to it

Recommendations for Education, Research, Business, and Government

<http://www.ifm.eng.cam.ac.uk/ssme/>

SSMEnetUK - <http://www.ssmenetuk.org>

- Funded by the UK Engineering and Physical Sciences Research Council (EPSRC)
- Focus on defining the SSME agenda in UK
<http://www.ssmenetuk.org/netactivity.asp>

The Challenge of Services in the 21st Century: Opportunities for Education and Business workshop

– July 1, 2008, University of Westminster

Establishing SSME as a new academic discipline: Thought Leadership Workshop

– September 17-18, 2008, Manchester Business School, University of Manchester

– Develop a blueprint for UK SSME education

- An agreed "requirement" from business and public sector organizations
- The scope of what comprises service science courses and what constitutes 'core' material

Karlsruhe Institute of Technology (KIT), Germany

Karlsruhe Services Research Institute (KSRI)

<http://www.ksri.uni-karlsruhe.de>

- Agreement signed by the University of Karlsruhe and IBM Germany on January 8, 2008 (PPP Model)
- The goal is to provide a service innovation hub both for researchers and practitioners, applying a holistic interdisciplinary approach
- Research focuses on the aspects of the "co-creation of value" that will significantly shape tomorrow's service industry (in an economic view) and are enabled or supported by ICT
- Graduate level modules Service Management and Service Engineering
 - SSME seminar jointly organized with IBM
- **First Karlsruhe Service Summit** on December 12, 2008

Services research programs in Germany

- Programs funded by the German Federal Ministry of Education and Research (BMBF)
 - **Services for the 21st Century** initiative - <http://www.dl2100.de/>
 - **Innovation through Services** research program announced in March 2006 (70M EUR over 4 years)
 - Workshop series “**Innovative Dienstleistungen auf dem Weg zur Weltspitze**”– 8 themes covering different service sectors (Sept. 2007 – Feb. 2008)
 -
- Service research at Fraunhofer Institute for Industrial Engineering (Fraunhofer-Institut für Arbeitswirtschaft und Organisation IAO)
 - Service Competence, Service Performance, Service Engineering
 - <http://www.dienstleistung.iao.fhg.de/english/profile.htm>
- Service curricula and research programs at many German universities
- First International Symposium on Services Science being organized by Leipzig University, March 23-25, 2009 - <http://iss.uni-leipzig.de/>

SSME in Finland

- **Serve** - Innovative Services Programme 2006-2010 funded by Tekes (Finish Funding Agency for Technology and Innovation)
<http://akseli.tekes.fi/opencms/opencms/OhjelmaPortaali/ohjelmat/Serve/en/etusivu.html>
- **Innovation University** announced in May 2008
 - Brings together the Helsinki University of Technology (HUT), Helsinki School of Economics (HSE) and the Helsinki University of Arts and Design
 - Three 'factories' defined to carry multidisciplinary program leveraging the skills of the three original universities – Design Factory, Media Factory and
 - **Service Factory** with Living Labs service paradigm
- Helsinki School of Economics, Master's program in Information and Service Management -
http://www.hse.fi/EN/education/programs/p_21/ismi/
- **BestServ Forum** – an innovation forum for industry and research for facilitating profitable growth through services - <http://www.bestserv.fi/>

University of Porto, Portugal - Faculty of Engineering (FEUP)

- Master in Engineering of Services and Management
 - approved by the Portuguese Ministry of Education in early 2007, started in September 2007 - <http://www.fe.up.pt/mesg>

1st Year

1st Semester

Management

Business Process Modeling
Information Systems
Organizational Behavior
Decision Support Systems
Human-Computer Interaction
Data Base Systems and Information Management
Creativity

2nd Semester

Service Operations Management and Logistics

Services Marketing
Accounting and Financial Management
Requirements Engineering for Services
Multimedia and New Services
Human Resources Management
Cognitive Psychology
Introduction to Research Project I

2nd Year

1st Semester

New Service Development and Design

Information Systems Architecture
Capital Budgeting
Enterprise Management Architecture
Corporate Strategy
Customer Relationship Management
Project Management Laboratory
E-Business Technologies
Introduction to Research Project II

2nd Semester

Dissertation – Research or Internship Project

Study plan from <http://gnomo.fe.up.pt/~mesg/studyplan.html>

Masaryk University, Czech Republic - Faculty of Informatics

- IT Service management course offered in 2007 in collaboration with the IBM Integrated Delivery Center (IDC) in Brno
- An SSME Master curriculum accredited in September 2008, courses starting Fall 2008
 - <http://kirlab.fi.muni.cz/en:ssme>
- Presented and discussed in a workshop in November 2007 with international participation
 - Collaboration / student exchange with FEUP planned

EPFL, Switzerland, School of Computer and Communication Sciences

- Enterprise and Service-Oriented Architecture Course
 - <http://lams.epfl.ch/course/eso2008>
 - <http://lams.epfl.ch/course/businessplan2008>

- Goal: understand the importance of business / IT alignment
 - have practical experience of important concepts and methods in business, business/IT alignment and IT (service-oriented) development
 - understand the underlying systemic modeling principles and the notion of **service** (at the IT level as well as at the business level)

- 14 weeks, 6 hours per week, immersive course
 - Students work in teams, play different roles in a fictitious company

- Described in detail in a publication
 - <http://www.via-nova-architectura.org/files/TEAR2007/Wegmann.pdf>

Services Focus in EU Programs and Initiatives

- Networked European Software and Services Initiative (NESSI)
<http://www.nessi-europe.com/>
 - A European Technology Platform (ETPs) initiative launched in September 2005 to foster economic growth and research in Services
 - 10 NESSI working groups
 - Services Sciences WG launched in 2006
 - NEXOF – NESSI Open Framework – the key target delivery
 - NEXOF Reference Architecture (NEXOF-RA) strategic project launched in March 2008, kick-off meeting October 20-21, 2008
http://www.nexof-ra.eu/open_construction_process
- ServiceWave 2008 conference – December 10-13, 2008
<http://www.servicewave.eu/>
 - Main theme: The future of the Internet of Services
- SSME International Workshop and Summer School (initiated by Prof. Christos Nikolaou, University of Crete)
 - 2007, Crete, Greece: The Business Process in the Science of Service
 - 2008, Palermo, Italy: Perspectives on Services



SSME Challenges

“SSME is just _____<name your discipline>_____”

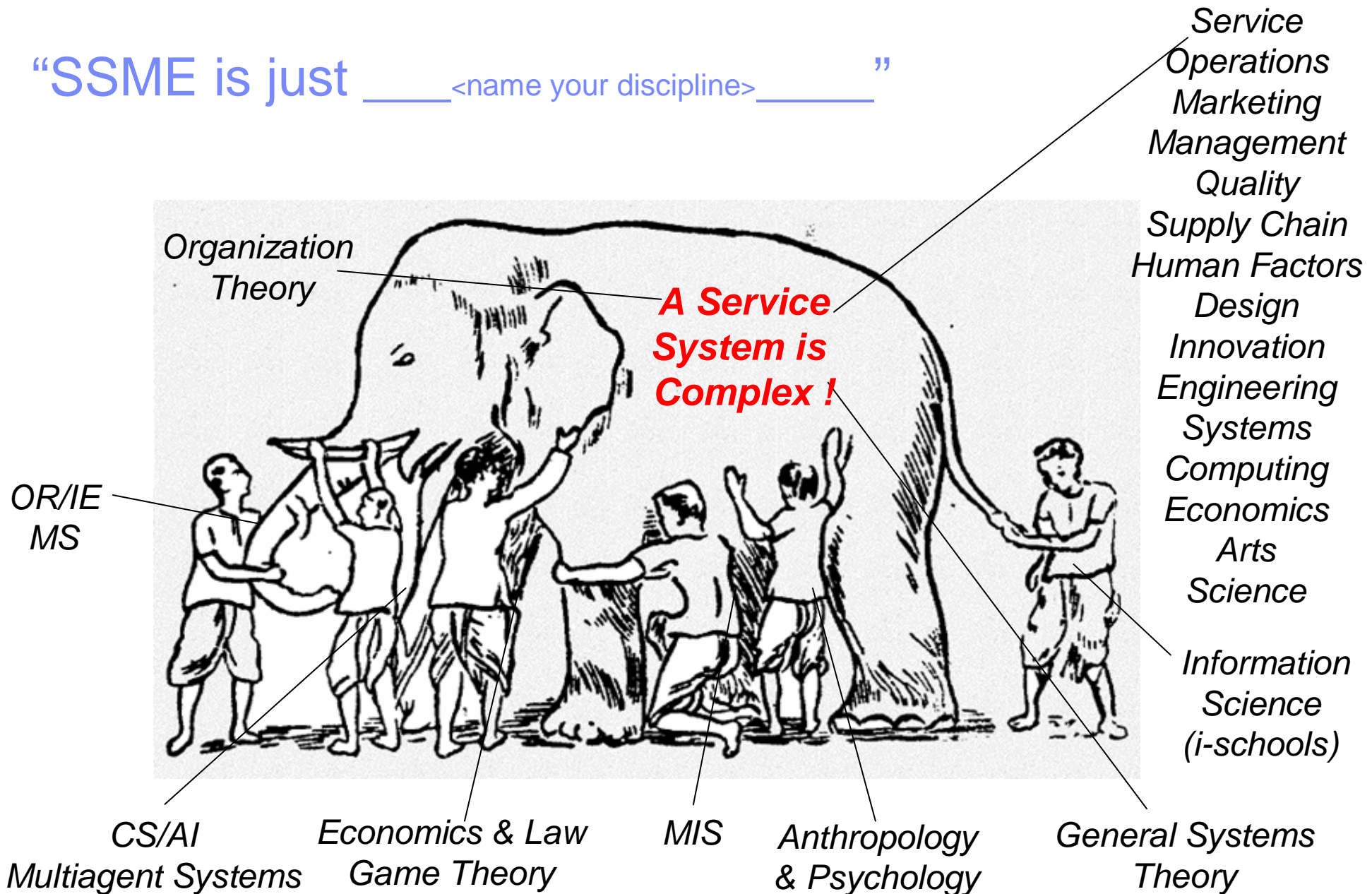

SSME Challenges

Service systems are complex adaptive systems - configurations of people, technology, internal and external service systems connected by value propositions and shared information (such as language, laws, measures, models)

The key to understanding service systems is to consider all these aspects as interacting parts

- **Current reality:** Disciplines tend to concentrate on particular resources categories and discipline-specific research agendas and language
 - This split is reflected also in conferences and journals
- **Needed: Interdisciplinary approach**
 - Create an appropriate set of new knowledge to bridge and integrate various areas based on transdisciplinary and crossdisciplinary collaboration
 - Cultivate *services mindset*

Service Science Discipline Classification System

A. General

1. Service Science Education
2. Research in Service Science
3. Service Science Policy
4. History of Services
5. Case Studies
6. Miscellaneous

B. Service Foundations

1. Service Theory
2. Service Philosophy
3. Economics of Services
4. Theoretical Models of Services
5. Mathematical Models of Services
6. Service Complexity Theory
7. Service Innovation Theory
8. Service Foundations Education

C. Service Engineering

1. Service Engineering Theory
2. Service Operations
3. Service Standards
4. Service Optimization
5. Service Systems Engineering
6. Service Supply Chains
7. Service Engineering Management
8. Service Systems Performance
9. Service Quality Engineering
10. New Services Engineering
11. Computer Services
12. Information Technology Services
13. Service Engineering Education

D. Service Management

1. Service Marketing
2. Service Operations
3. Service Management
4. Service Lifecycle
5. Service Innovation Management
6. Service Quality
7. Human Resources Management
8. Customer Relationship Management
9. Services Sourcing
10. Services Law
11. Globalization of Services
12. Service Business Education

E. Human Aspects of Services

1. Service Systems Evolution
2. Behavioral Models of Services
3. Decision Making in Services
4. People in Service Systems
5. Organizational Change in Services
6. Social Aspects of Services
7. Cognitive Aspects of Services
8. Customer Psychology
9. Education in Human Aspects of Services

F. Service Design

1. Service Design Theory
2. Service Design Methodology
3. Service Representation
4. Aesthetics of Services
5. Service Design Education

G. Service Arts

1. Service Arts Theory
2. Traditional Service Arts
3. Performance Arts
4. History of Service Arts
5. Service Arts Education

H. Service Industries*

1. The Service Industry
2. Utilities
3. Wholesale Trade
4. Retail Trade
5. Transportation and Warehousing
6. Information Services
7. Finance and Insurance
8. Real Estate and Rental
9. Professional and Technical Services
10. Management Services
11. Administrative and Support Services
12. Educational Services
13. Health Care and Social Assistance
14. Arts, Entertainment, and Recreation
15. Accommodation and Food Services
16. Public Administration Services
17. Other Service Industries

* service industries based on NAICS 07

Claudio Pinhanez, Paul Kontogiorgis, IBM
Presented at 2008 Frontiers in Services,
October 5-7, 2008.

Some SSME Research Topics

- **CAD for service systems**
 - To design and test new service systems, to simulate new business models, business processes
- **Global communication tools**
 - What are the barriers to highly productive human-human coordination in service systems? What kind of tools will help to overcome them?
- **Service workforce management**
 - Application of supply chain methods to service supply chains (people-centered)
 - What factors do we need to take into account in composing and optimizing teams?
- **Effective service automation**
 - Tradeoffs in human vs computer effort in creating and operating services
 - What are the limits to self-service? How much work can we shift to end-users?
- **Automation tools for data mining / data analysis**
 - Speed the understanding of where service improvements or optimization is needed
 - Discover opportunities for new services

Example: Work Systems in Service Delivery

- **Formal processes – important to efficiency and costs**

- e.g. ITIL, Business Processes Modeling [*Top-down, plan and integrate*]

ITIL Change Management

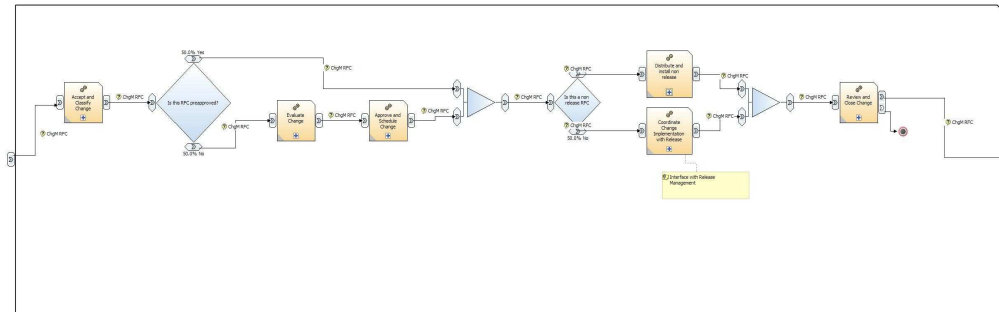

- **Informal collaboration in business and personal contexts**

- e.g. Instant Messaging, WIKI, Web Forums, Blogs, etc. [*Bottom-up, viral*]

Unstructured Activities



Next generation collaboration will occur in business applications, tightly integrated, in the context of work being conducted, incorporating formal and informal aspects of work.

Example: A supply-chain approach to increase the effectiveness of workforce management

- ▶ **More accurate resource analysis**
- ▶ **Better forecasting of demand**
- ▶ **Optimized management of resources to opportunities**

But since people are not parts, learning, motivation and reputation are crucial

- ▶ **Learning paths for skills in demand**
 - ▶ **Skills taxonomy, skills affinity**
- ▶ **Work-based learning systems**
- ▶ **Methods for applying best work practices**

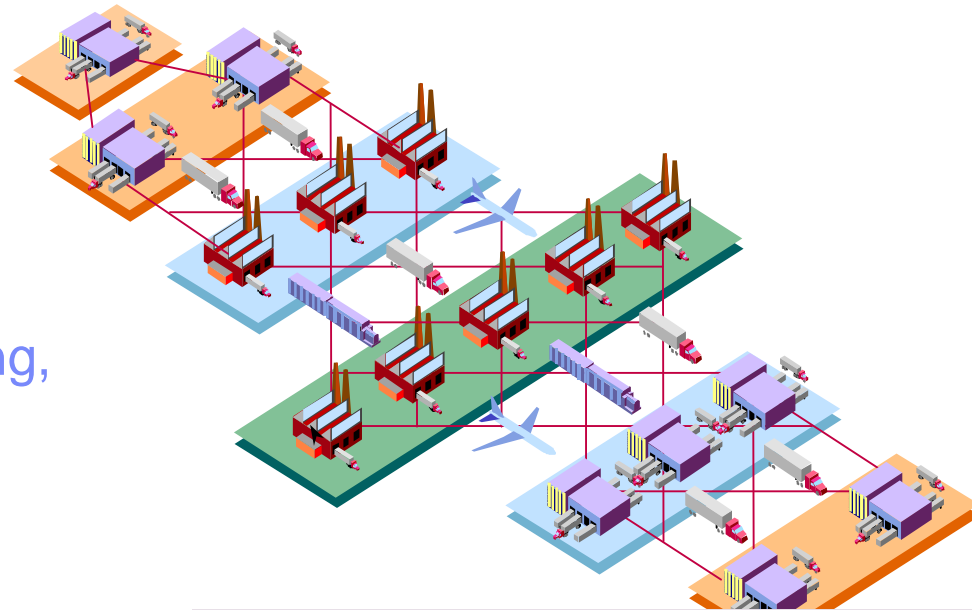

intelligent
enterprise

January 2006

<http://www.intelligententerprise.com/showArticle.jhtml?articleID=175002433>

Optimizing the Human Supply Chain

Supply chain thinking inspires workforce optimization.

By [Michael Voelker](#)

Skills for the 21th Century

- **Technical talent needed more than ever - but nature of that talent is changing**
- **Growing demand for new generation of innovators with deep knowledge of service related disciplines**

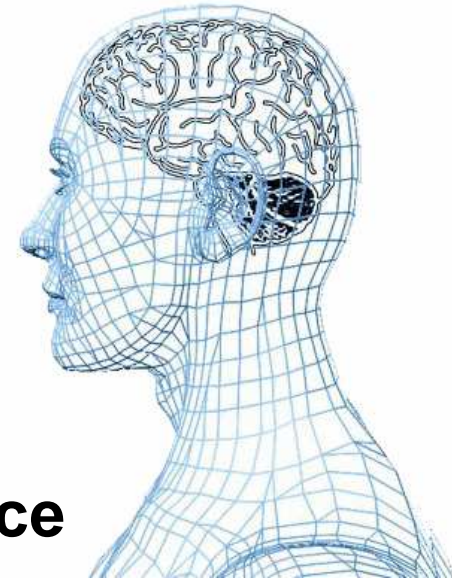

"IT professionals will need to possess expertise in multiple domains. Technical aptitude alone will no longer be enough. IT professionals must prove they can understand business realities – industry, core processes, customer bases, regulatory environment, culture and constraints. Versatility will be crucial." – Gartner Group IT Professional Outlook, 2005